

# MHD/MDD/MDP CONNECTOR SERIES

*PCB High Density Connectors*

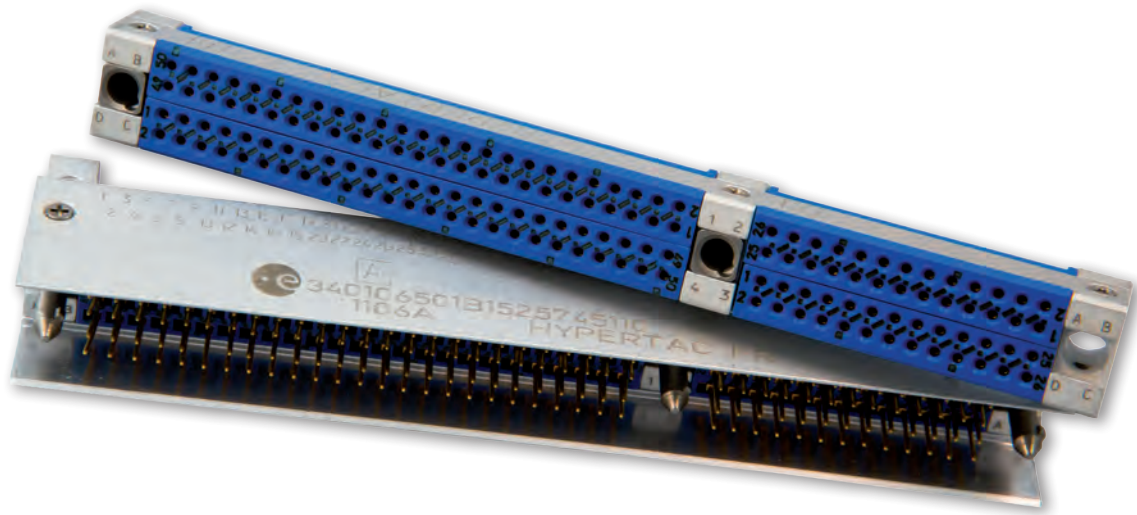

# HYPERBOLOID TECHNOLOGY

Smiths Connectors offers an extensive range of superior contact technologies suitable for standard and custom solutions. Hypertac® (HYPERboloid conTACT) is the original superior performing hyperboloid contact technology designed for use in all applications and in harsh and demanding environments where high reliability and safety are critical. The inherent electrical and mechanical characteristics of the Hypertac hyperboloid contact ensures unrivalled performance in terms of reliability, number of mating cycles, low contact force and minimal contact resistance. The shape of the contact sleeve is formed by hyperbolically arranged contact wires, which align themselves elastically as contact lines around the pin, providing a number of linear contact paths.

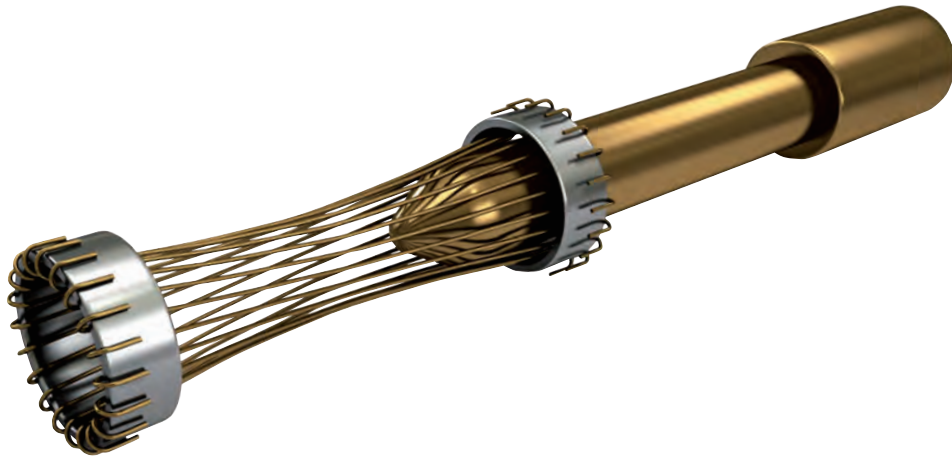

## FEATURE

### LOW INSERTION/EXTRACTION FORCES

The angle of the socket wires allows tight control of the pin insertion and extraction forces. The spring wires are smoothly deflected to make line contact with the pin.

### LONG CONTACT LIFE

The smooth and light wiping action minimizes wear on the contact surfaces. Contacts perform up to 100,000 insertion/extraction cycles with minimal degradation in performance.

### LOWER CONTACT RESISTANCE

The design provides a far greater contact area and the wiping action of the wires insures a clean and polished contact surface. Our contact technology has about half the resistance of conventional contact designs.

### HIGHER CURRENT RATINGS

The design parameters of the contact (e.g., the number, diameter and angle of the wires) may be modified for any requirement. The number of wires can be increased so the contact area is distributed over a larger surface. Thus, the high current carried by each wire because of its intimate line contact, can be multiplied many times.

### IMMUNITY TO SHOCK & VIBRATION

The low mass and resultant low inertia of the wires enable them to follow the most abrupt or extreme excursions of the pin without loss of contact. The contact area extends 360° around the pin and is uniform over its entire length. The 3 dimensional symmetry of the Hypertac contact design guarantees electrical continuity in all circumstances.

## BENEFIT

### HIGH DENSITY INTERCONNECT SYSTEMS

Significant reductions in size and weight of sub-system designs. No additional hardware is required to overcome mating and un-mating forces.

### LOW COST OF OWNERSHIP

The Hypertac contact technology will surpass most product requirements, thus eliminating the burden and cost of having to replace the connector or the entire subsystem.

### LOW POWER CONSUMPTION

The lower contact resistance of our technology results in a lower voltage drop across the connector reducing the power consumption and heat generation within the system.

### MAXIMUM CONTACT PERFORMANCE

The lower contact resistance of the Hypertac contact reduces heat build-up; therefore Hypertac contacts are able to handle far greater current in smaller contact assemblies without the detrimental effects of high temperature.

### RELIABILITY UNDER HARSH ENVIRONMENTS

Harsh environmental conditions require connectors that will sustain their electrical integrity even under the most demanding conditions such as shock and vibration. The Hypertac contact provides unmatched stability in demanding environments when failure is not an option.

# TABLE OF CONTENTS

## MHD SERIES

- ▶ Technical characteristics .....2
- ▶ How to order .....3
- ▶ Modules configuration.....4
- ▶ Standard plugging stages .....5
- ▶ Termination styles.....6
- ▶ Connector dimensions .....7
- ▶ Guiding devices .....13
- ▶ Contact board preparation details.....14
- ▶ Power and high frequency contacts.....18

## MDD SERIES

- ▶ Technical characteristics .....19
- ▶ How to order .....20
- ▶ Modules configuration.....21
- ▶ Standard plugging stages .....22
- ▶ Termination styles.....23
- ▶ Connector dimensions .....24
- ▶ Guiding devices .....25
- ▶ Contact board preparation details.....26

## MDP SERIES

- ▶ Technical characteristics .....27
- ▶ How to order .....28
- ▶ Connector dimensions .....29
- ▶ Guide and termination styles .....30
- ▶ Contact board preparation details.....31

# TECHNICAL CHARACTERISTICS

MATERIALS & PLATINGS	
<b>Insulator</b>	Diallyl Phtalate UL94vo
<b>Frame</b>	Aluminium Alloy
<b>Contact</b>	Copper Alloy
<b>Guide</b>	Brass + Ni or Stainless steel
<b>Contact plating</b>	Ni + Au

ENVIRONMENTAL	
<b>Temperature range</b>	- 55° C to +125° C
<b>Safety of contact from extraction</b>	Statical 2 mm / 0.079" Dynamical 1.80 mm / 0.071"
<b>Mating cycles</b>	5000
<b>Withdrawal forces</b>	≤ 0.5 N
<b>Special contacts</b>	According to NFC 93569

ELECTRICAL	
<b>Contact resistance</b>	Signal ≤ 12 mΩ Power ≤ 2 mΩ
<b>Current rating</b>	Signal 3 A Power 15 A
<b>Insulation</b>	>10 <sup>4</sup> MΩ
<b>Voltage rating</b>	200 V
<b>Proof voltage</b>	800 V
<b>Contact diameter</b>	Signal 0.50 mm Power 2.00 mm
<b>Impedance</b>	Coaxial 50 Ω

Dimension are in mm

# HOW TO ORDER

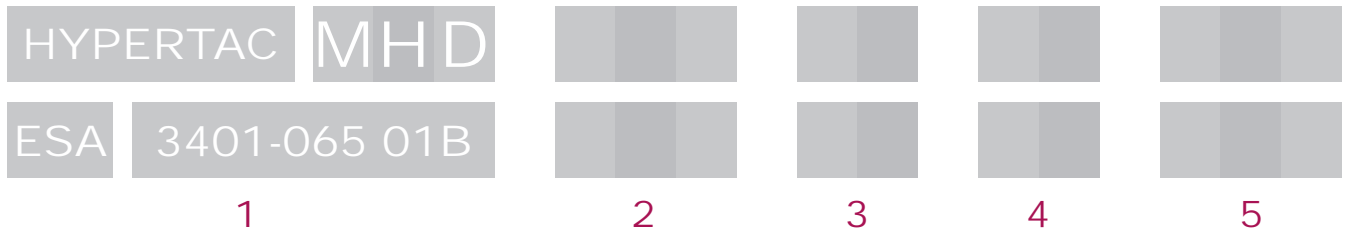

## 1 ▸ SERIES

## 2 ▸ ARRANGEMENT

- € 052
- € 152
- € 252
- € 352
- 5HA
- 1HB
- 6XA
- € 100
- € 200
- € 300
- € 400
- 2XA
- 7XB
- 3HB

## 3 ▸ PART - POLARITY - PLATING

1 3	€ 5 5	Male Plug standard plating	2 2	€ 4 4	Female Receptacle - Standard plating
1 7	€ 5 7	Male Plug - Pretinned	2 6	€ 4 6	Female Receptacle - Pretinned

## 4 ▸ TERMINATION STYLES

€ 1 0	90° termination, PCB thickness 1.60	€ 3 1	Straight termination, PCB thickness 3.20	4 4	SMT* - uncentered PCB thickness 3.80
€ 1 1	90° termination, PCB thickness 2.40	4 1	SMT* - PCB thickness 1.60	€ 4 5	SMT* - uncentered PCB thickness 1.60
€ 1 2	90° termination, PCB thickness 3.20	4 2	SMT* - PCB thickness 3.20	€ 4 7	SMT* - uncentered PCB thickness 2.40
€ 3 0	Straight termination, PCB thickness 2.40	€ 4 3	SMT* - PCB thickness 2.40	€ 9 1	Female / male saver**

## 5 ▸ GUIDE STYLES

- € 1 1 0 MALE POLARISED, TRANSVERSE MOUNT, STANDARD PLUG
- € 1 1 1 MALE POLARISED, VERTICAL MOUNT
- € 1 2 1 FEMALE POLARISED, VERTICAL MOUNT
- 1 2 2 FEMALE POLARISED, VERTICAL MOUNT
- € 1 2 4 FEMALE POLARISED, TRANSVERSE MOUNT
- 1 2 5 MALE UNPOLARISED, TRANSVERSE MOUNT
- 1 2 6 FEMALE UNPOLARISED, VERTICAL MOUNT
- 1 3 0 FEMALE ALL POLARISED, VERTICAL MOUNT
- 1 3 1 FEMALE ALL POLARISED, VERTICAL MOUNT
- 1 3 3 FEMALE ALL POLARISED, TRANSVERSE MOUNT
- € 1 3 4 FEMALE POLARISED, TRANSVERSE MOUNT
- 1 9 0 FEMALE POWER OR MASS CONTACT, VERTICAL MOUNT
- 1 9 1 MALE POWER OR MASS CONTACT, TRANSVERSE MOUNT
- € 2 0 1 ¼ TURN, FREE CONNECTOR

\* Surface Mount Termination  
 \*\* Consult us - PCB thickness is in mm

► MODULES CONFIGURATION

SINGLE ARRANGEMENTS

RECEPTACLE - MATING SIDE VIEWS

MIXED ARRANGEMENTS

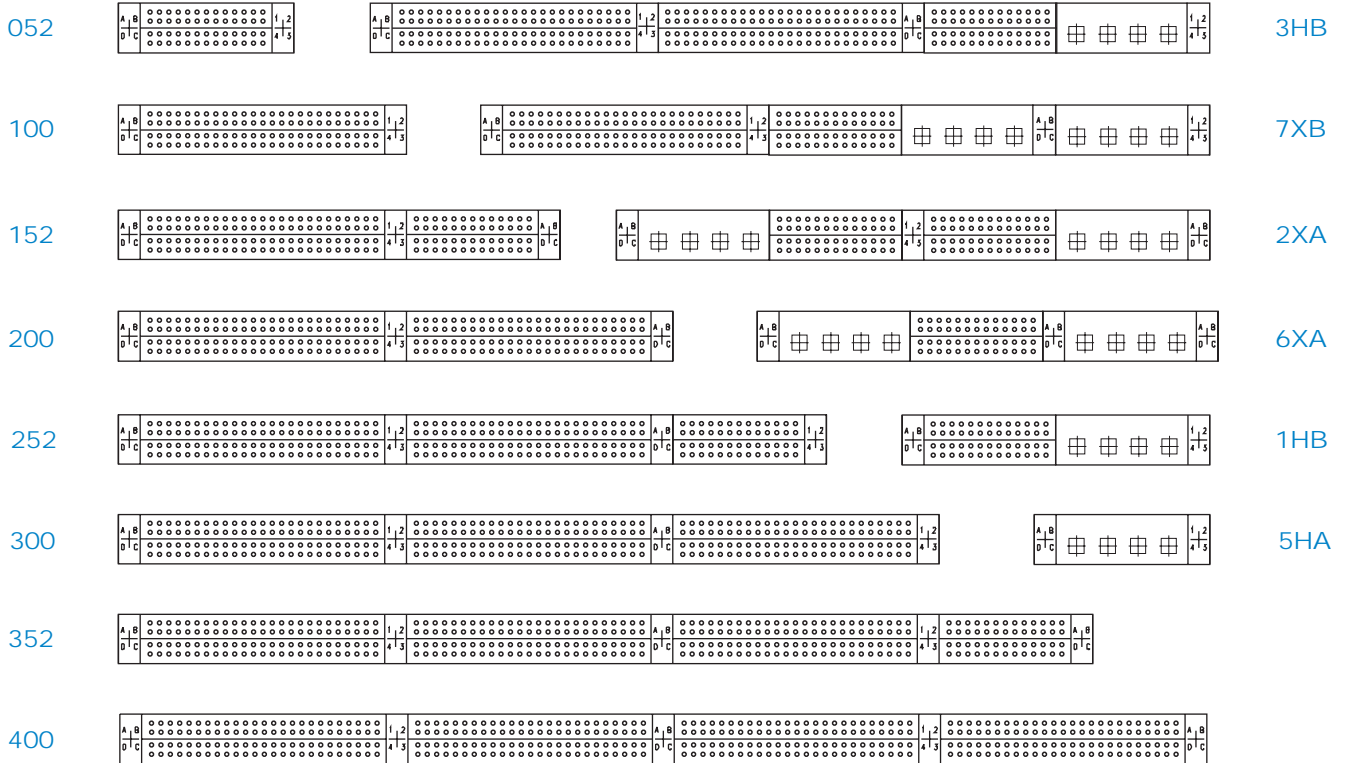

26 ways module

50 ways module

4 ways module (special contacts)

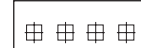
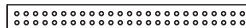
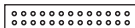

Space which can receive:

- 2x50 ways module
- or
- 2x26 ways module
- 1x4 ways module
- or
- 2x4 ways module



Space which can receive:

- 2x26 ways module
- or
- 1x4 ways module

STANDARD PLUGGING STAGES

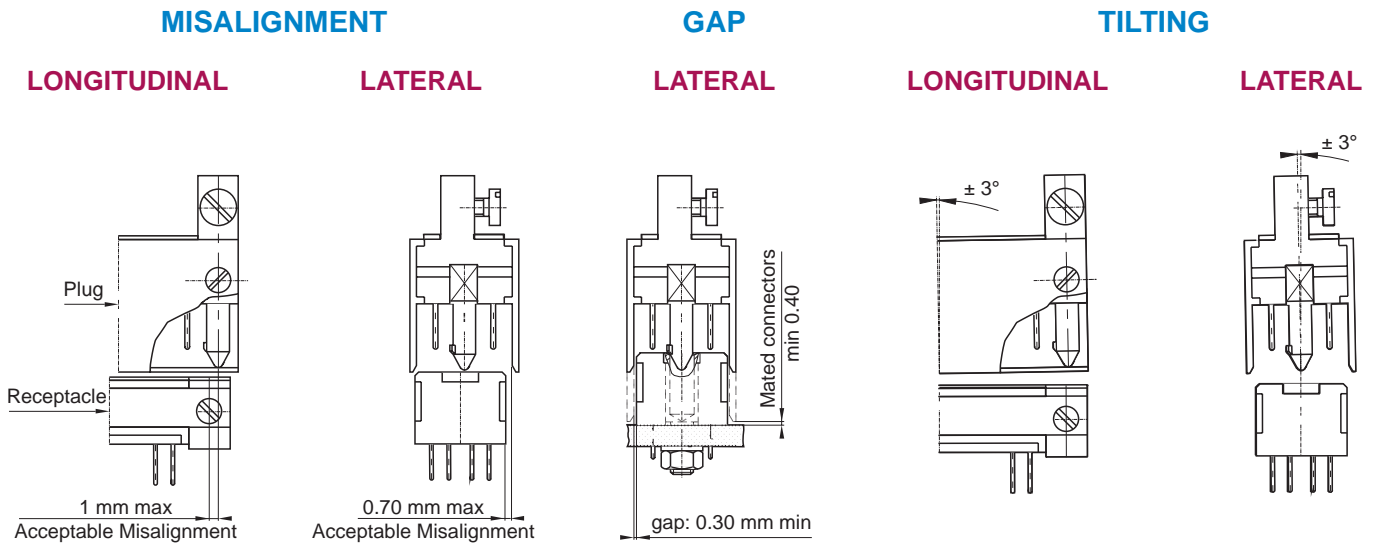

MOUNTING EXAMPLES

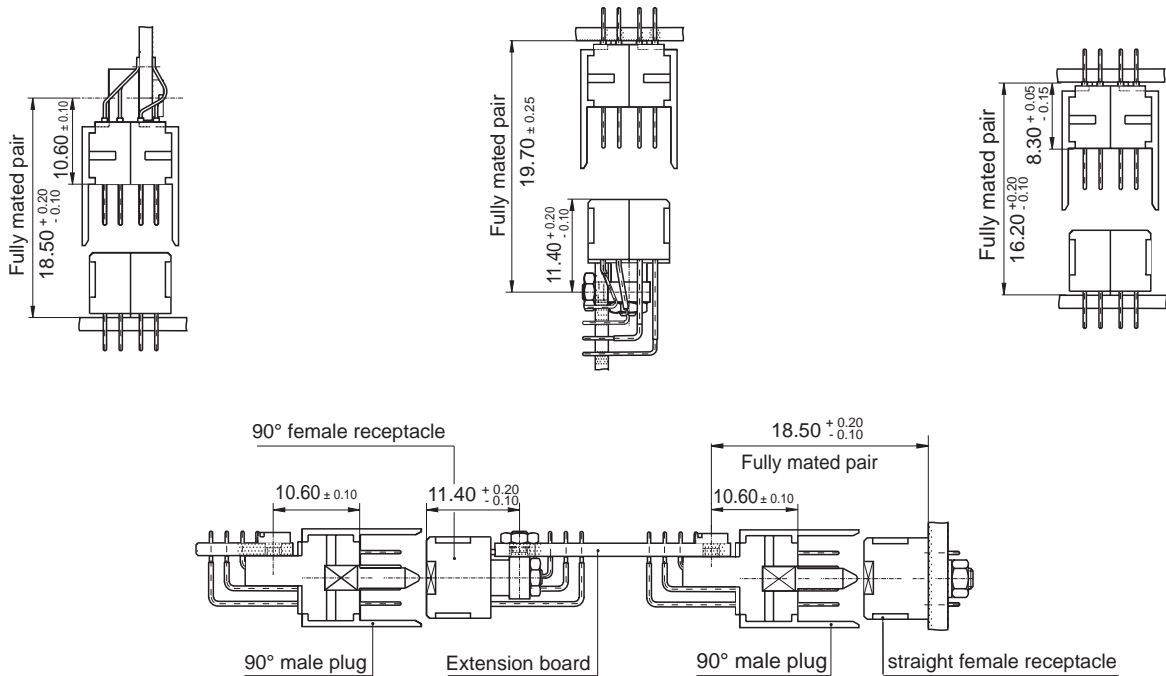

DISPLACEMENT

Max displacement allowed while plugging in the receptacle: 0.15 mm in all plugged in connector ways.

TERMINATION STYLES

RECEPTACLE

THROUGH BOARD SOLDER - 90°

Ref: 10  
PCB: 1.44 - 1.76  
A =  $3.25^{+0.15}_{-0.45}$   
B = 6 max

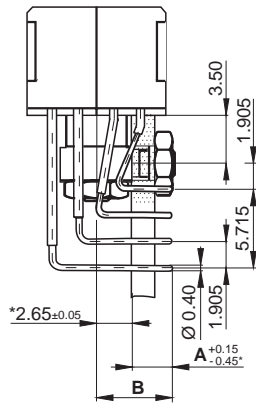

Ref: 11  
PCB: 1.98 - 2.42  
A =  $3.85^{+0.15}_{-0.45}$   
B = 6.60 max

THROUGH BOARD SOLDER - STRAIGHT

Ref: 30  
PCB: 2.16 - 2.64  
A = 3.50 min  
4.00 max

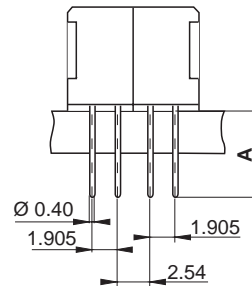

Ref: 31  
PCB: 2.88 - 5.50  
A = 6.10 min  
6.60 max

PLUG

THROUGH BOARD SOLDER - 90°

Ref: 10  
PCB: 1.44 - 1.76  
A = 5.95 max

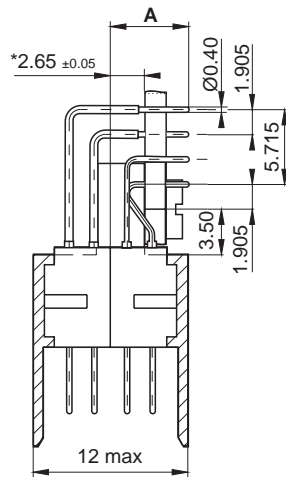

Ref: 12  
PCB: 2.88 - 3.52  
A = 7.60 max

THROUGH BOARD SOLDER - STRAIGHT

Ref: 30  
PCB: 2.16 - 2.64  
A = 3.50 min  
4.00 max

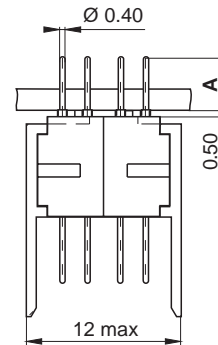

Ref: 31  
PCB: 2.88 - 3.52  
A = 4.60 min  
5.10 max

SURFACE MOUNT (CENTERED PCB)

Ref: 41  
PCB: 1.44 - 1.76  
A = 5.20 max

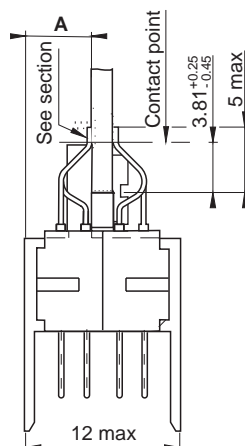

Ref: 42  
PCB: 2.88 - 3.52  
A = 4.40 max

Ref: 43  
PCB: 2.16 - 2.64  
A = 4.80 max

SURFACE MOUNT (UNCENTERED PCB)

Ref: 44  
PCB: 3.60 - 4.00  
A = 4.40 max

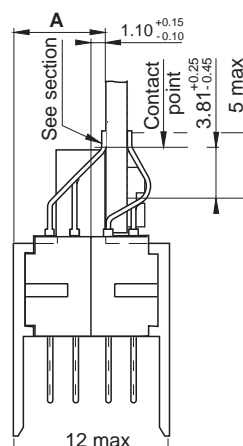

Ref: 45  
PCB: 1.44 - 1.76  
A = 7 max

Ref: 47  
PCB: 2.16 - 2.64  
A = 7 max

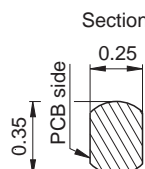



CONNECTOR DIMENSIONS

PLUG

52 CONTACTS

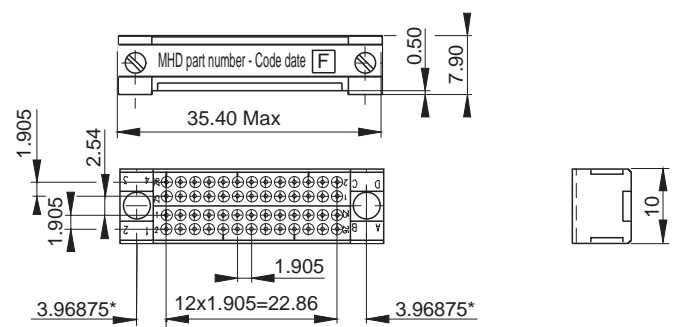
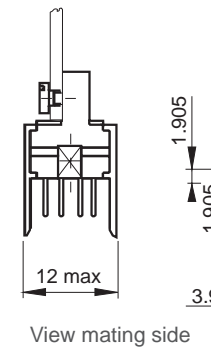
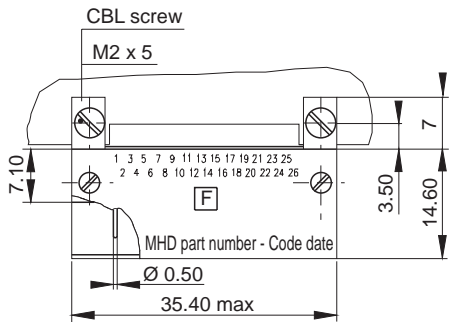

100 CONTACTS

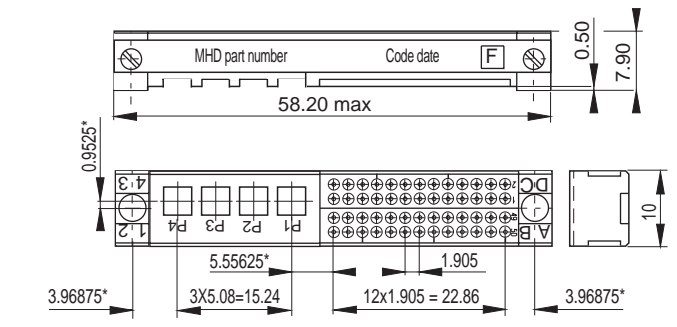
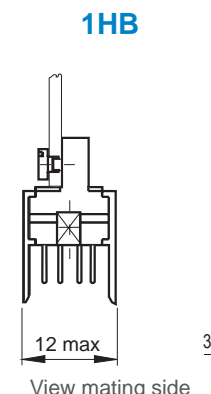
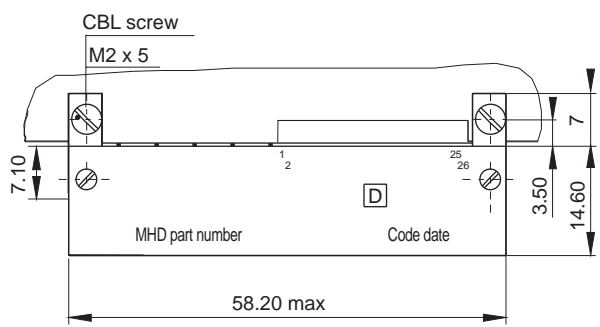
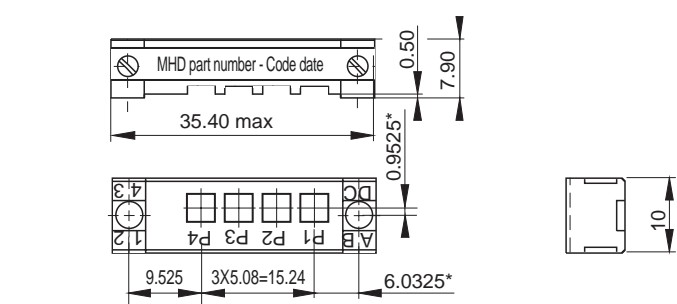
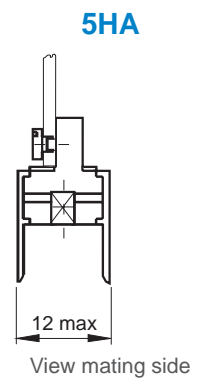
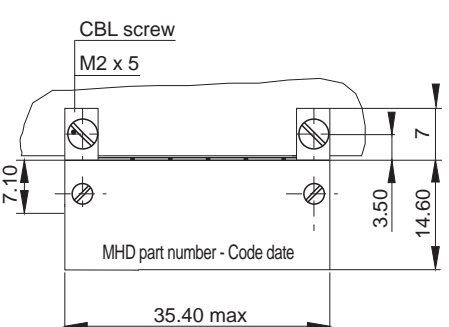
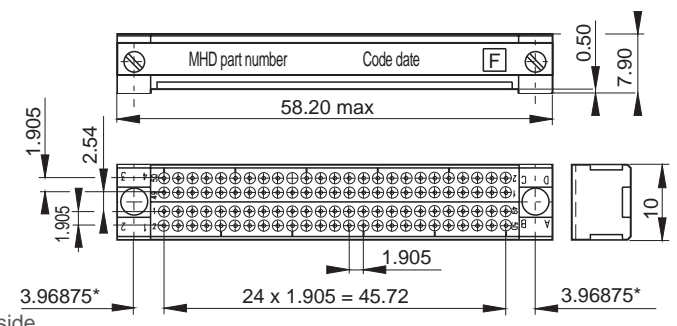
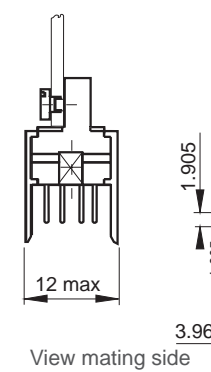
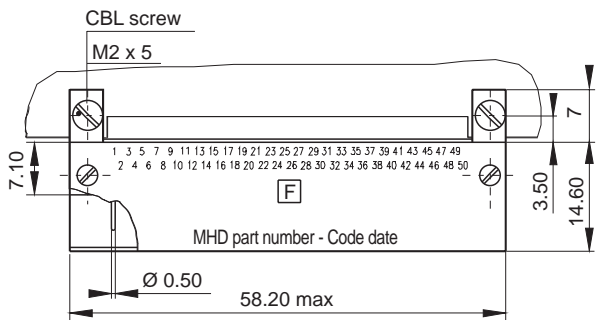

\* Theoretical dimensions  
The termination side contact configurations are specified on board preparation details.

CONNECTOR DIMENSIONS

152 CONTACTS

PLUG

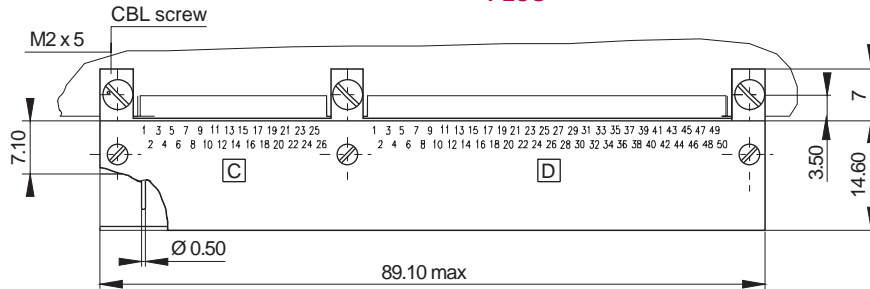

RECEPTACLE

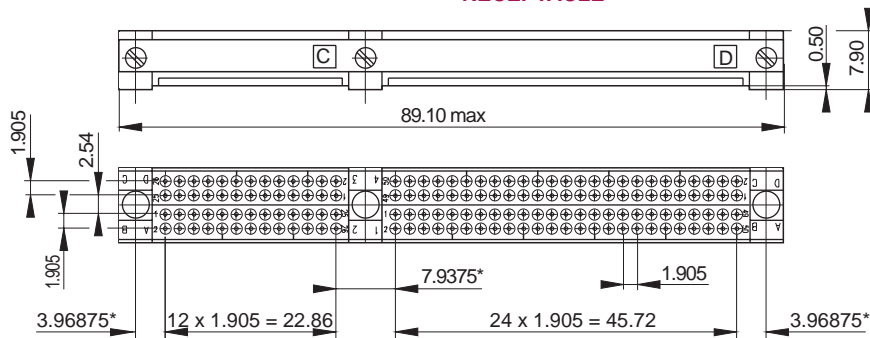

View mating side

6XA

PLUG

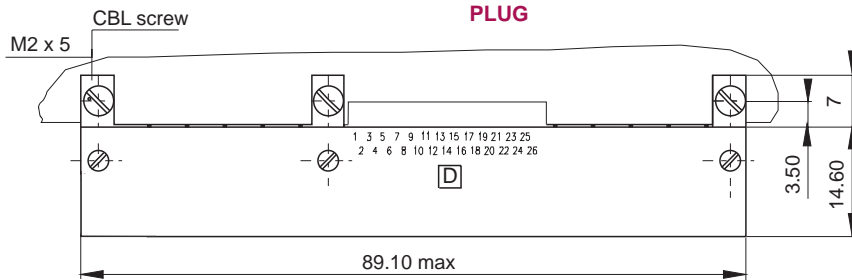

RECEPTACLE

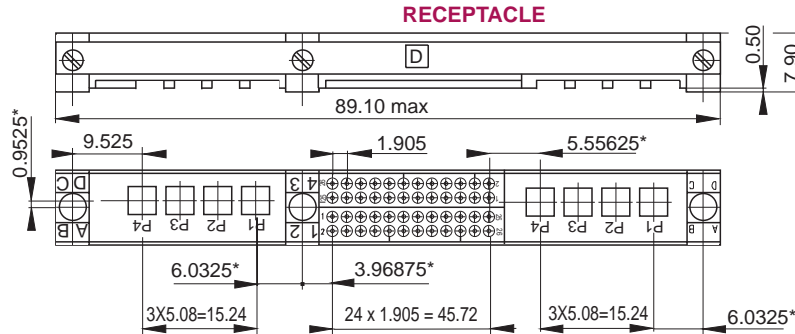

View mating side

\* Theoretical dimensions

The termination side contact configurations are specified on board preparation details.

CONNECTOR DIMENSIONS

200 CONTACTS

PLUG

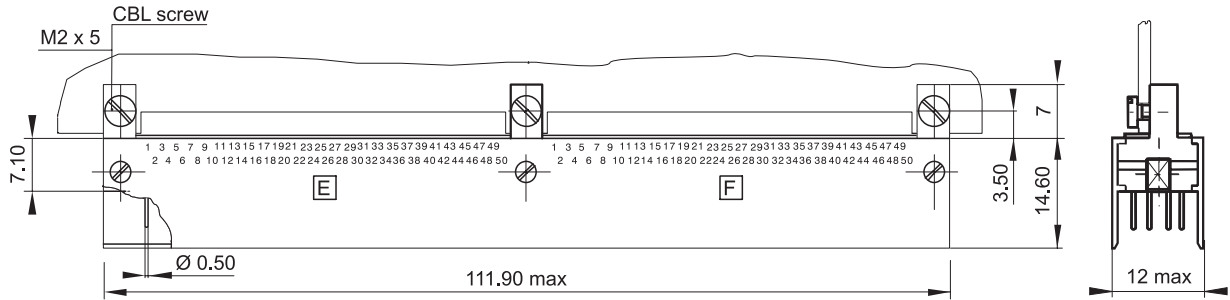

RECEPTACLE

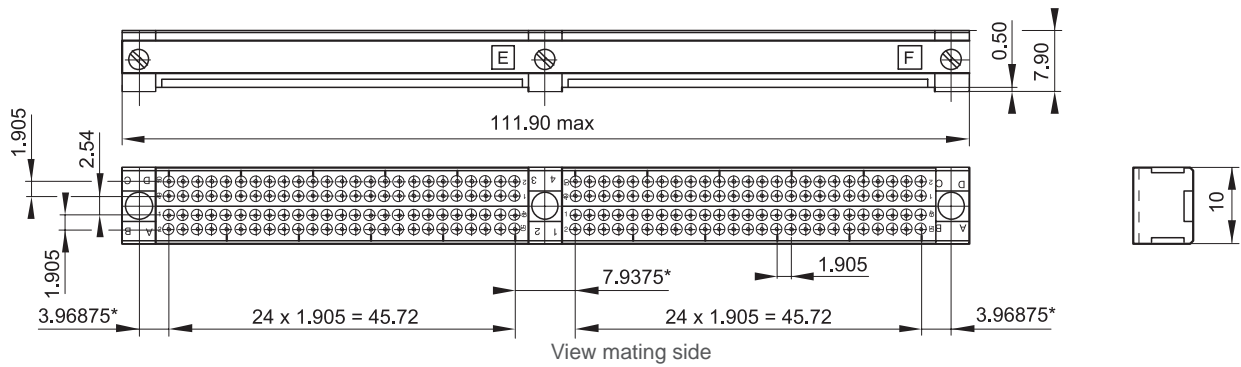

2XA

PLUG

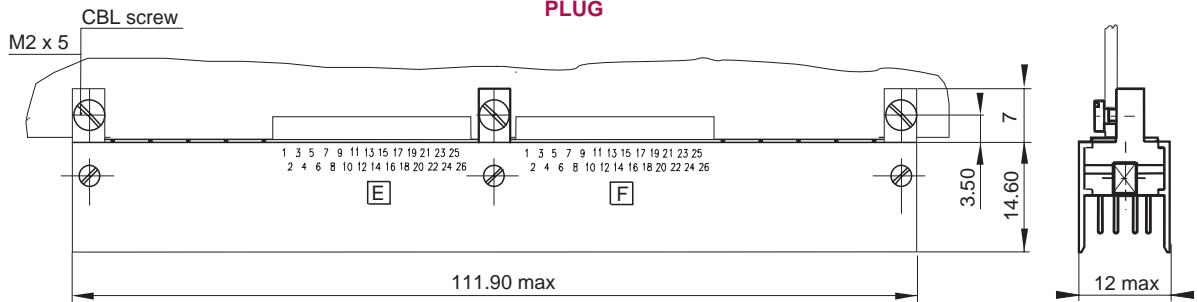

RECEPTACLE

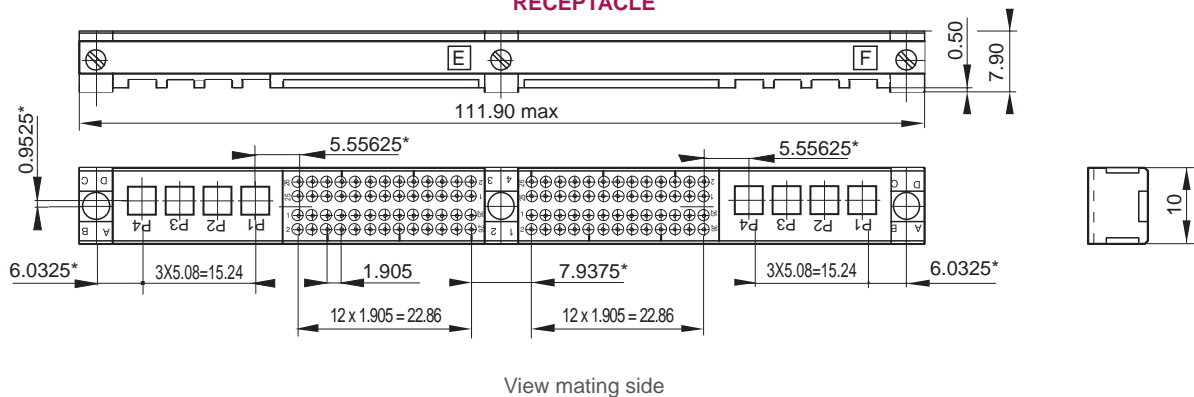

\* Theoretical dimensions  
The termination side contact configurations are specified on board preparation details.

CONNECTOR DIMENSIONS

252 CONTACTS

PLUG

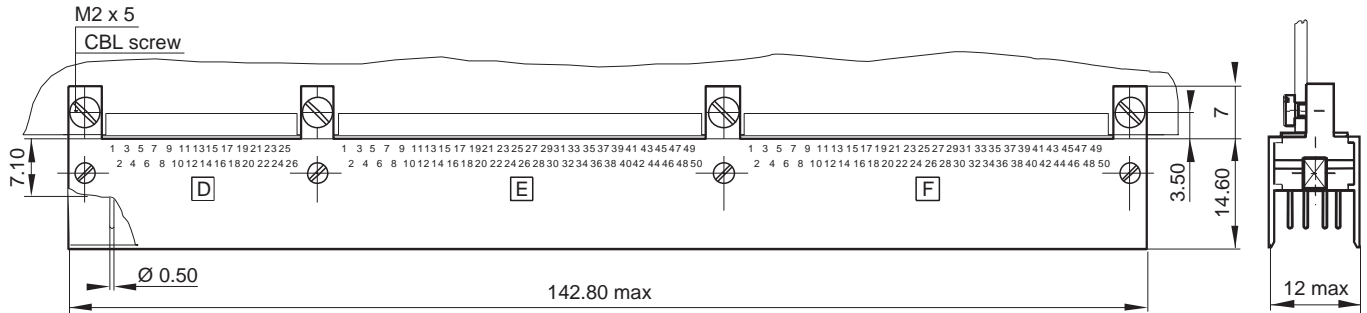

RECEPTACLE

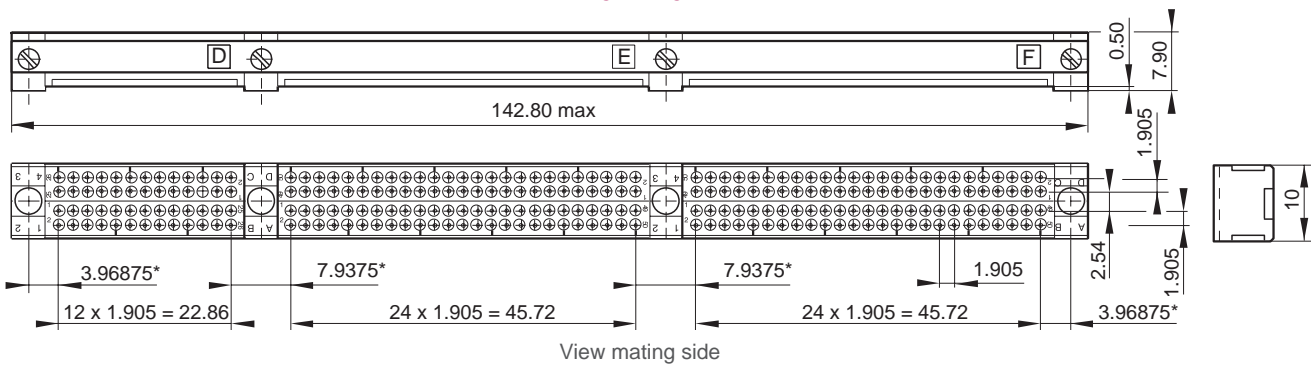

7XB

PLUG

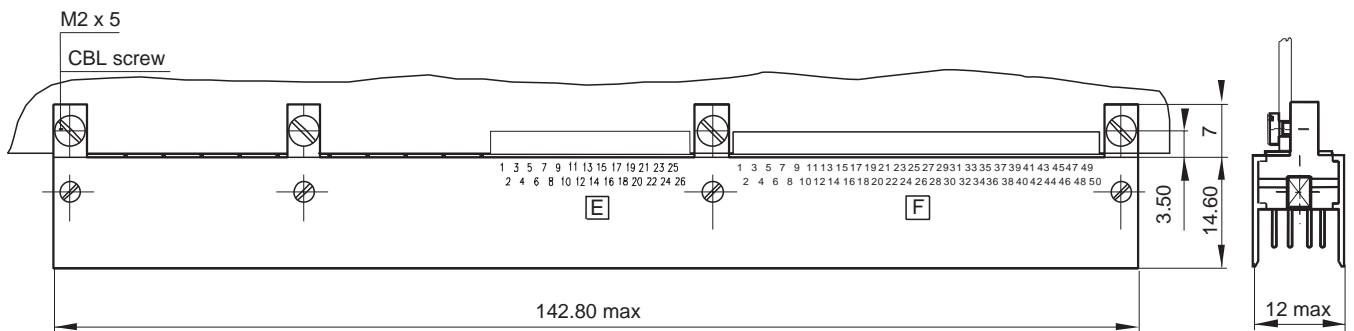

RECEPTACLE

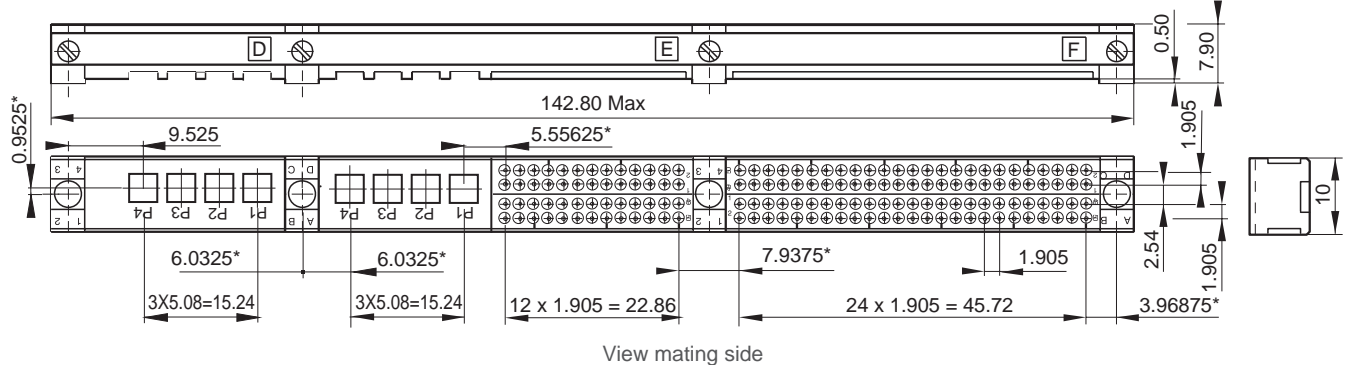

\* Theoretical dimensions  
The termination side contact configurations are specified on board preparation details.

CONNECTOR DIMENSIONS

300 CONTACTS

PLUG

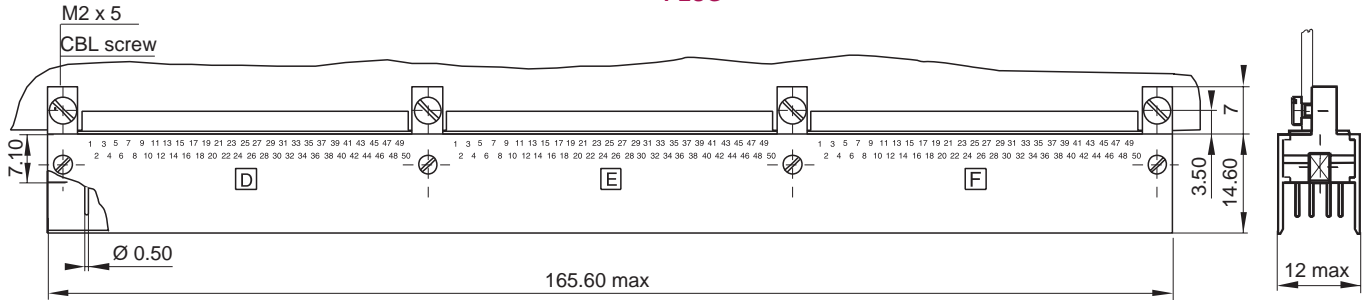

RECEPTACLE

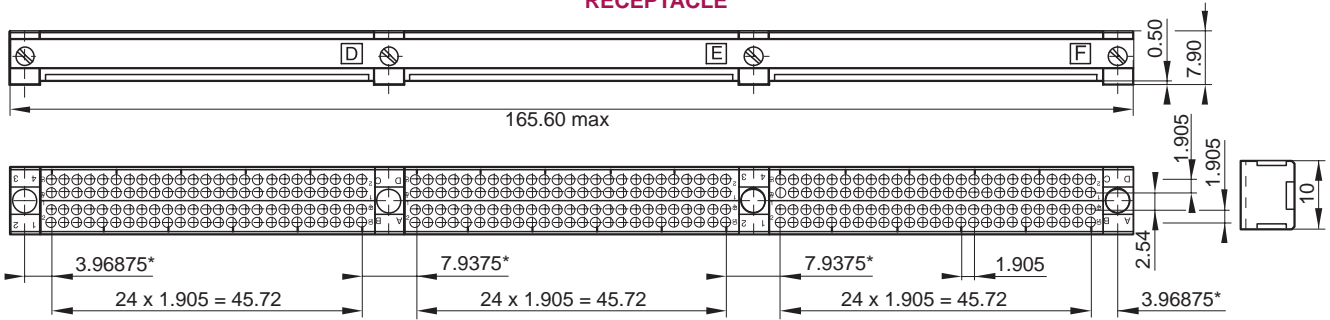

View mating side

3HB

PLUG

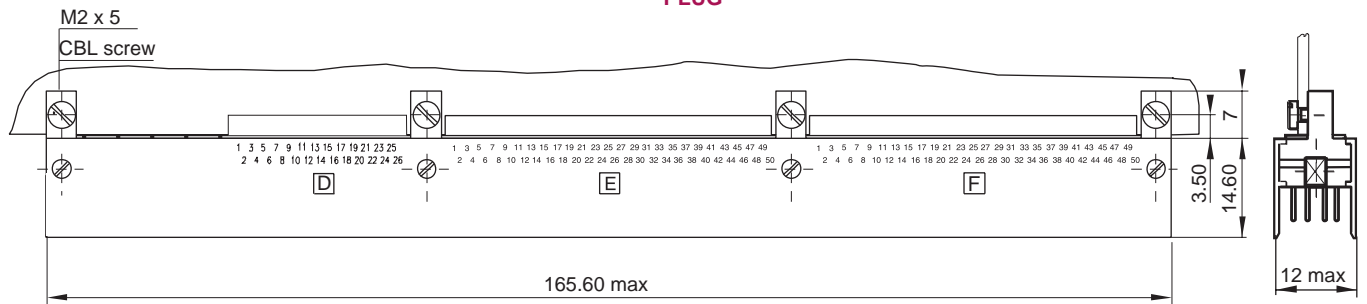

RECEPTACLE

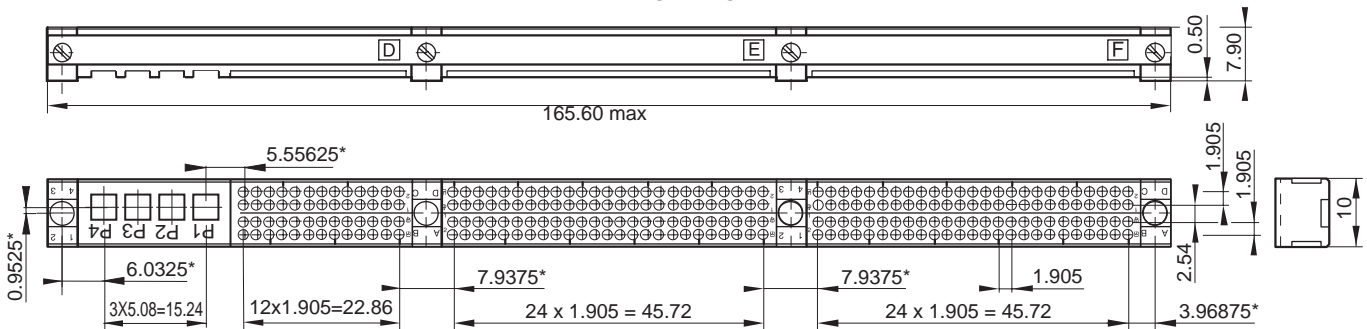

View mating side

\* Theoretical dimensions  
The termination side contact configurations are specified on board preparation details.

CONNECTOR DIMENSIONS

352 CONTACTS

400 CONTACTS

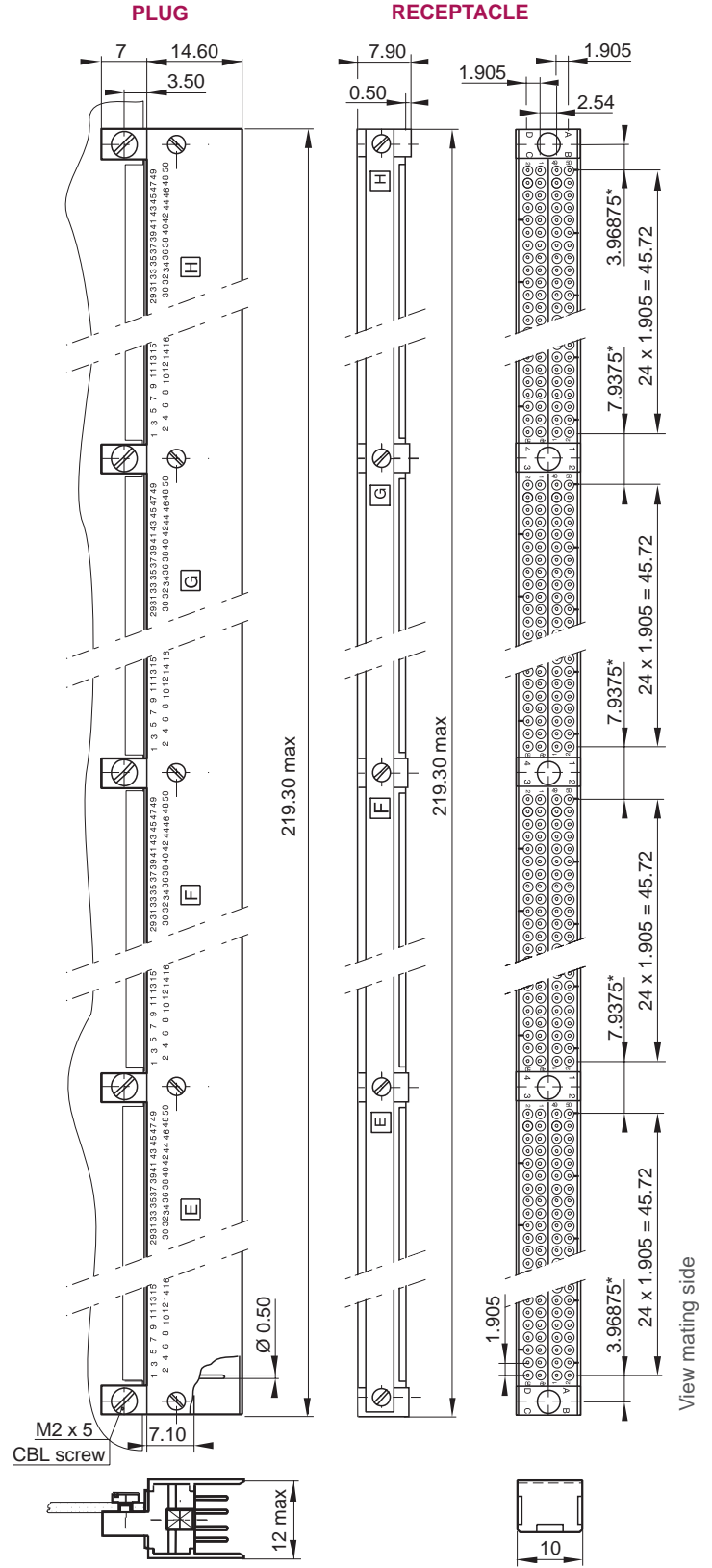
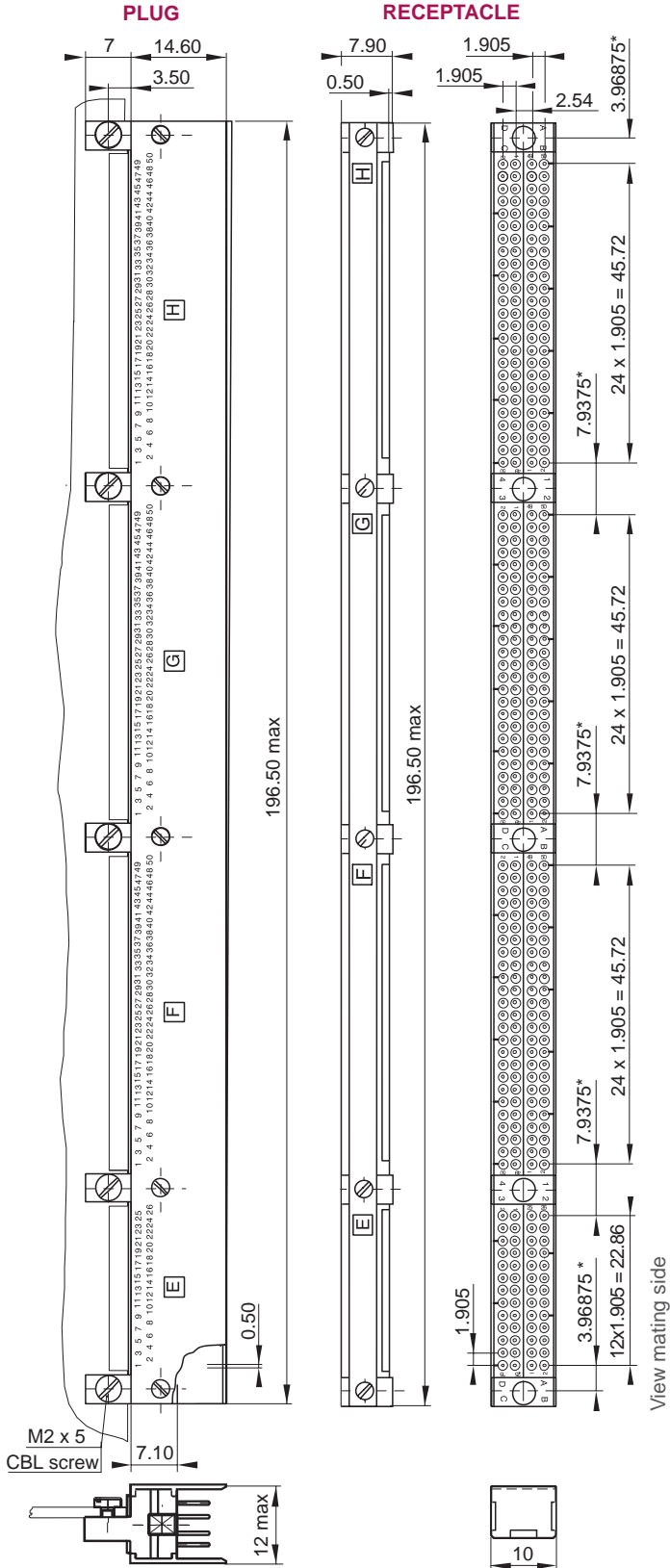

\* Theoretical dimensions  
The termination side contact configurations are specified on board preparation details.

► GUIDING DEVICES

RECEPTACLE

**MHD 00- \_\_ 121**

Polarised female guide vertical mounting (Length: 5.50)

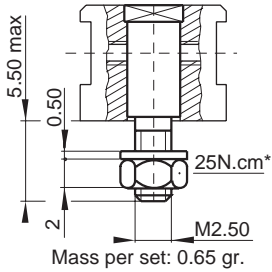

**MHD 00- \_\_ Z122**

Polarised female guide vertical mounting (Length: 7)

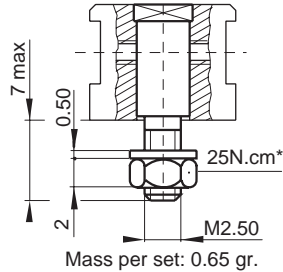

**MHD 00- \_\_ Z124 / Z134**

Polarised female guide transverse mounting P/N 124: A=6; 134: A=6.60

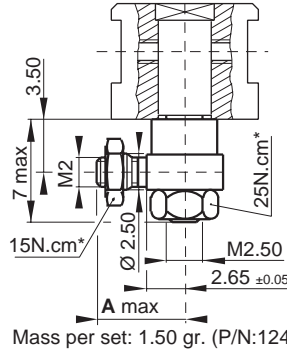

**MHD 00- \_\_ Z126**

Unpolarised female guide vertical mounting

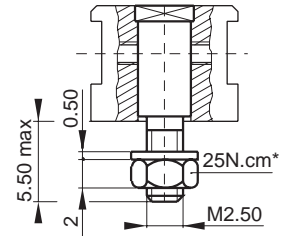

**MHD 00- \_\_ Z130**

All polarity female guide vertical mounting (Length: 5.50)

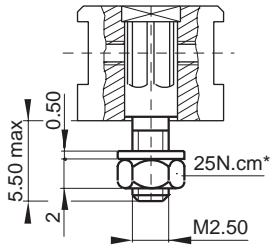

**MHD 00- \_\_ Z131**

All polarity female guide vertical mounting (Length: 7)

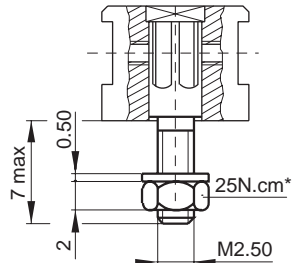

**MHD 00- \_\_ Z133**

All polarity female guide transverse mounting

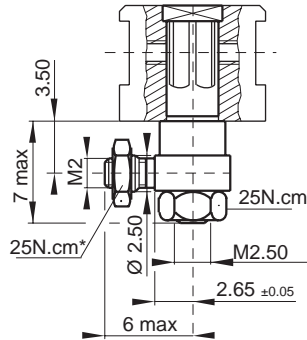

**MHD 00- \_\_ Z190**

Ground female guide vertical mounting

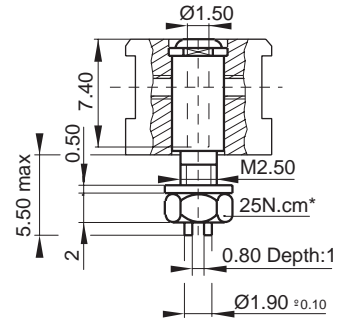

PLUG

**MHD 00- \_\_ 110**

Polarised male guide transverse mounting

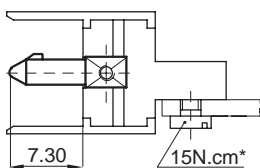

Mass per set: 0.55 gr.

**MHD 00- \_\_ Z111**

Polarised male guide vertical mounting

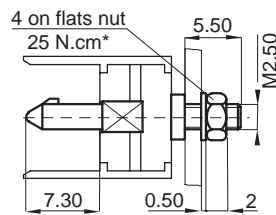

Mass per set: 1.35 gr.

**MHD 00- \_\_ Z125**

Unpolarised male guide transverse mounting

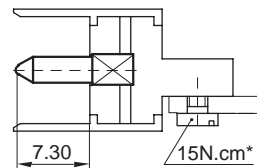

Mass per st: 0.55 gr.

**MHD 00- \_\_ Z191**

Ground male contact transverse mounting

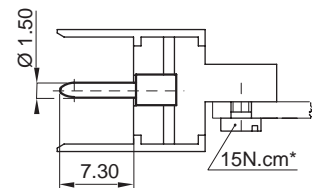

\* Theoretical dimensions

► 52 CONTACT BOARD PREPARATION DETAILS (1)

RECEPTACLE

STRAIGHT TERMINATION

Guides: 121, 122, 126, 130, 131, 190

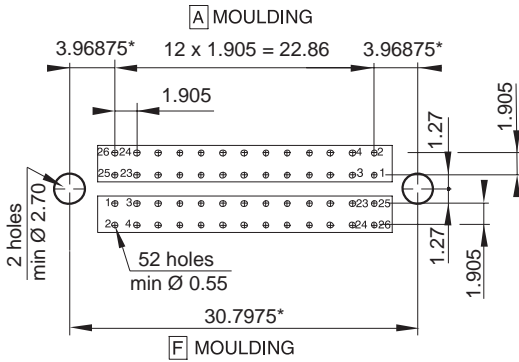

90° TERMINATION

Guides: 124, 133, 134

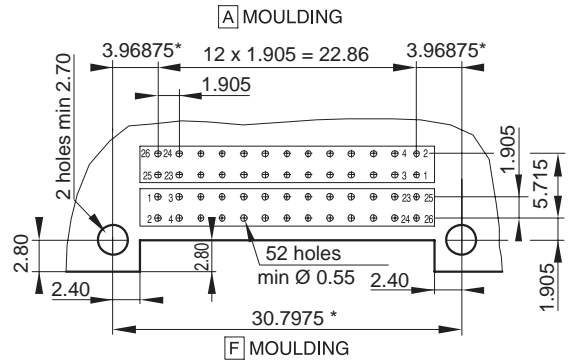

PLUG

STRAIGHT TERMINATION

Guides: 111

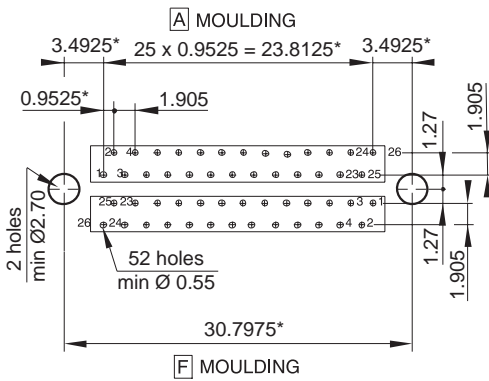

90° TERMINATION

Guides: 110, 125, 191

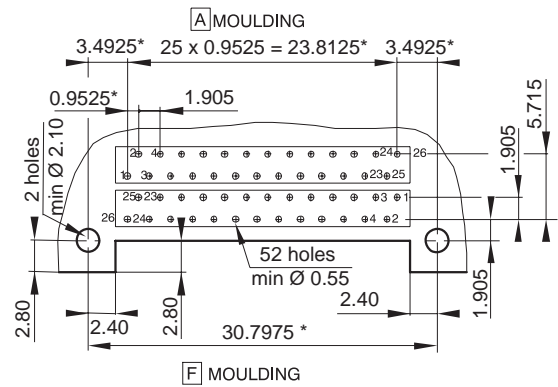

SURFACE MOUNT TERMINATION

Guides: 110, 125, 191

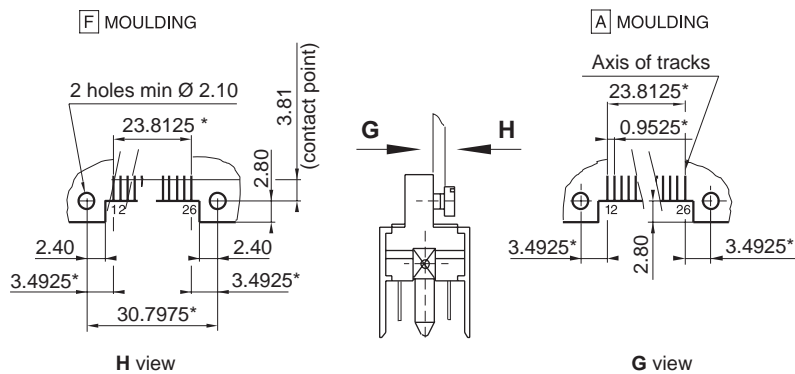

(1) Important note: See important note on 1HB preparation board details (page 17).

\* Theoretical dimensions



► 5HA CONTACT BOARD PREPARATION DETAILS <sup>(1)</sup>

RECEPTACLE

STRAIGHT TERMINATION

Guides: 121, 122, 126, 130, 131, 190

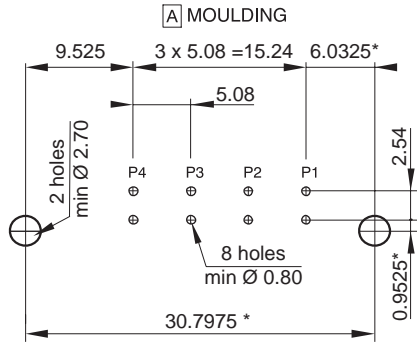

90° TERMINATION

Guides: 124, 133, 134

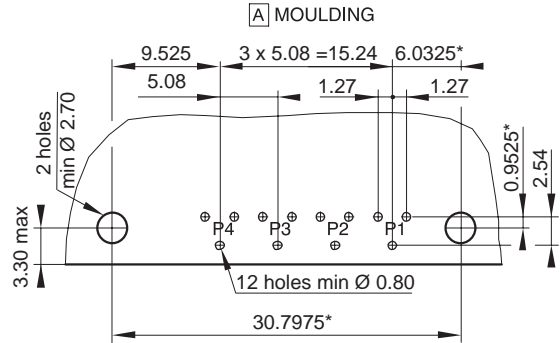

PLUG

90° TERMINATION

Guides: 110, 125, 191

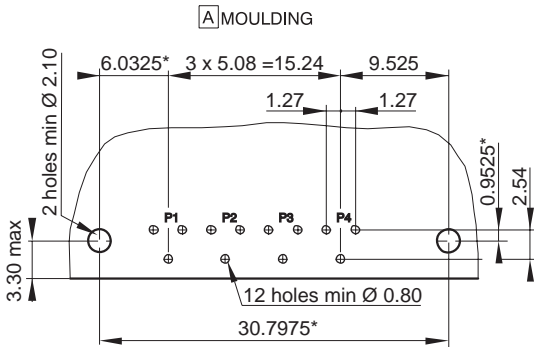

SURFACE MOUNT TERMINATION

Guides: 110, 125, 191

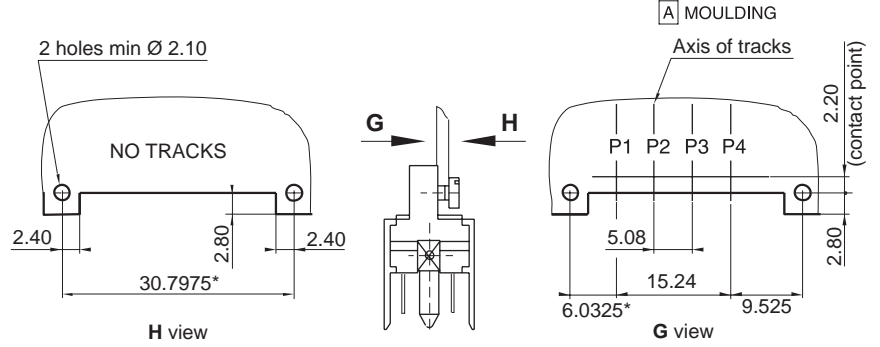

<sup>(1)</sup> Important note: See important note on 1HB preparation board details (page 17).

\* Theoretical dimensions

▶ 100 CONTACT BOARD PREPARATION DETAILS <sup>(1)</sup>

RECEPTACLE

STRAIGHT TERMINATION

Guides: 121, 122, 126, 130, 131, 190

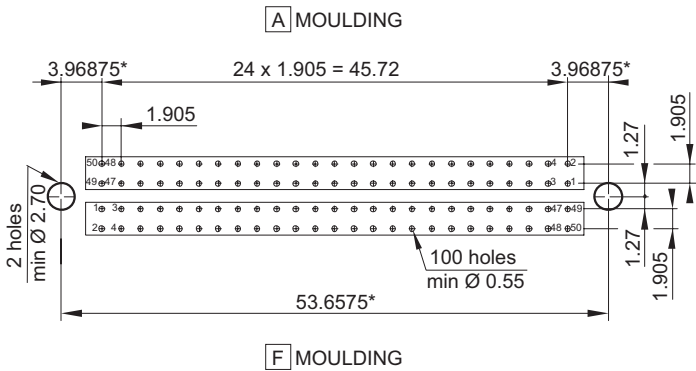

90° TERMINATION

Guides: 124, 133, 134

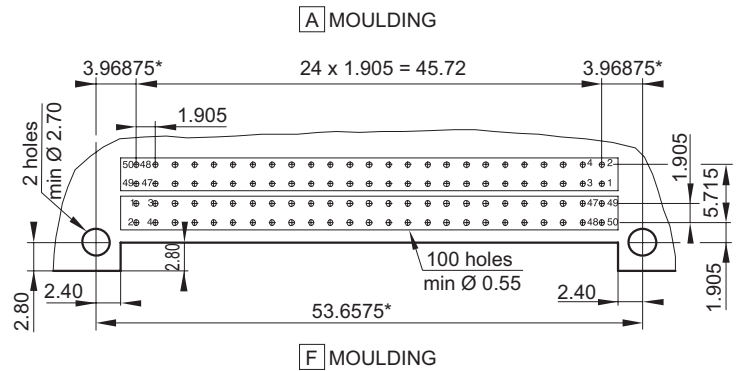

PLUG

STRAIGHT TERMINATION

Guides: 111

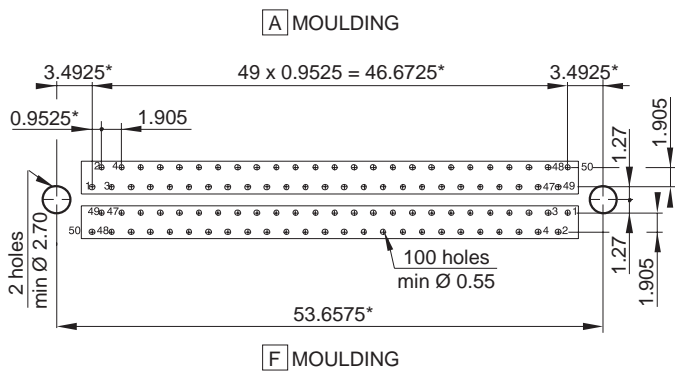

90° TERMINATION

Guides: 110, 125, 191

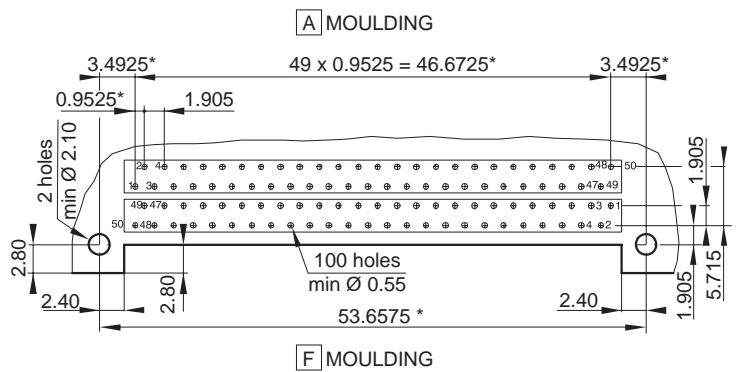

SURFACE MOUNT TERMINATION

Guides: 110, 125, 191

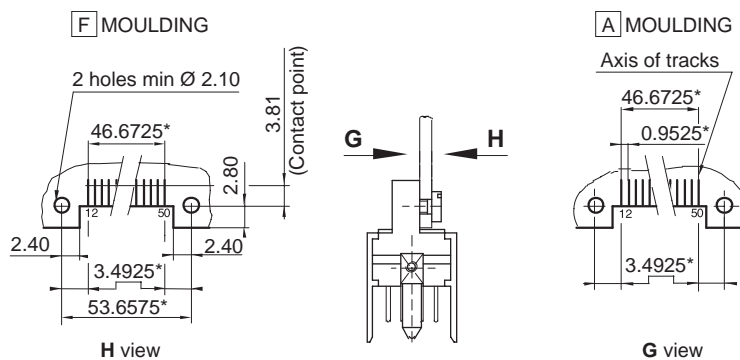

(1) Important note: See important note on 1HB preparation board details (page 17).

\* Theoretical dimensions

▶ 1HB CONTACT BOARD PREPARATION DETAILS <sup>(1)</sup>

RECEPTACLE

STRAIGHT TERMINATION

Guides: 121, 122, 126, 130, 131, 190

A MOULDING

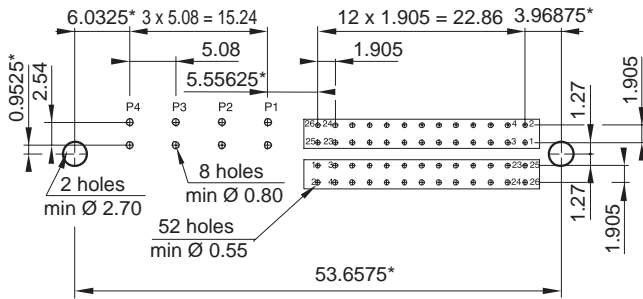

D MOULDING

90° TERMINATION

Guides: 124, 133, 134

A MOULDING

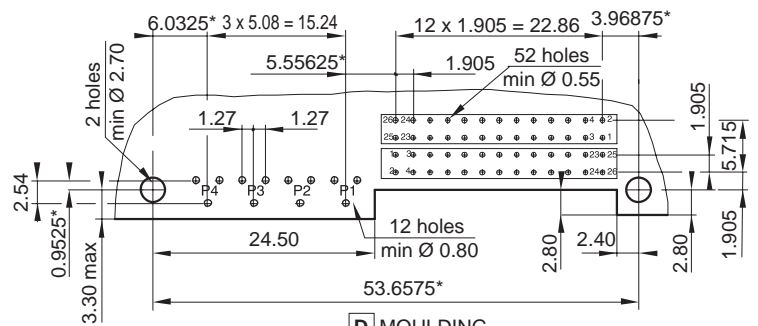

D MOULDING

PLUG

90° TERMINATION

Guides: 110, 125, 191

A MOULDING

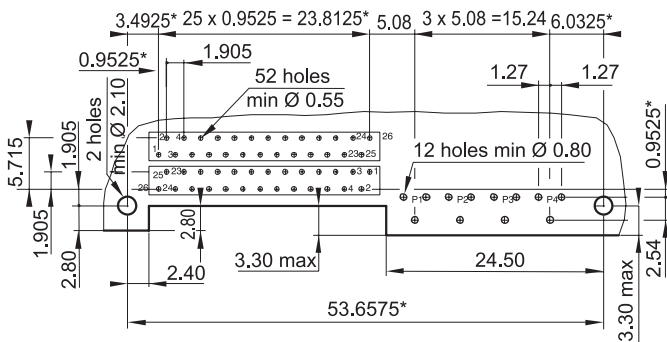

D MOULDING

SURFACE MOUNT TERMINATION

Guides: 110, 125, 191

D MOULDING

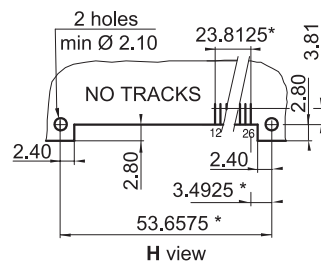

A MOULDING

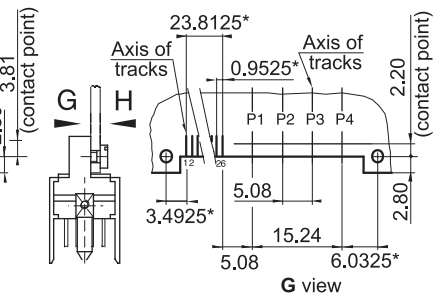

**(1) Important note:** Drilling layouts shown concern the following full configurations: 052, 5HA, 100, 1HB, 200. Other arrangements, shown on “MODULES CONFIGURATION” page, require a specific drilling layout to ensure the correct mounting of the chosen connector, that you must obtain from our technical department. However, the drilling layouts shown above should help you to achieve the desired configuration. For that, you may have to mix those drilling layouts to obtain the right configuration.

\* Theoretical dimensions

► POWER & HIGH FREQUENCY CONTACTS (NFC 93569)

EXAMPLE OF CONTACT OVERVIEW (020 084 2. 10 R--)

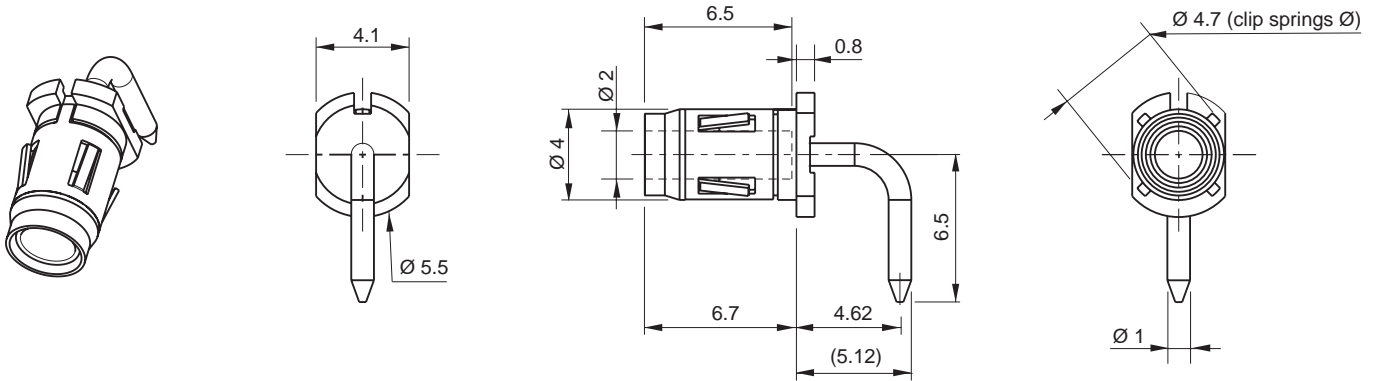

POWER CONTACTS

Male	P/N	Female	P/N
90° termination	020 085 1- 10R OG	90° termination	020 084 2- 10R G1
Straight termination	020 087 1- 30R OG	Straight termination	020 056 2- 30R G1
Solder bucket termination	020 091 1- 40R OG	Solder bucket termination	020 060 2- 40R G1

HIGH FREQUENCY CONTACTS

	Male P/N	Female P/N
Vertical mounting, suitable for flexible cable Ø 1.9 max. Ref. KX 21 A (Rg 178 B/U or RG 196).	KMX 3-M 081	KMX 3-F 081
Transverse mounting, suitable for flexible cable Ø 1.9 max. Ref. KX 21 A (Rg 178 B/U or RG 196). Usable with mother board, thickness 3.2 mm max.	KMX 3-M 092	KMX 3-F 092
Vertical mounting, suitable for flexible cable Ø 2.5 max. Ref. KX 22 A (RG 316).	KMX 3-M 101	KMX 3-F 101
Transverse mounting, suitable for flexible cable Ø 2.5 max. Ref. KX 22 A (RG 316). Usable with mother board, thickness 3.2 mm max.	KMX 3-M 112	KMX 3-F 112
Vertical mounting, suitable to semi-rigid cable Ø 2.2 max. Ref. Ks 1 A (RG 405 - UT 85).	KMX 3-M 131	KMX 3-F 131
Transverse mounting, suitable to semi-rigid cable Ø 2.2 max. Ref. Ks 1 A (RG 405 - UT 85). Usable with mother board, thickness 3.2 mm max.	KMX 3-M 142	KMX 3-F 142
Straight termination tail for direct mounting on to PCB	KMX 3-M 041	KMX 3-F 041
90° termination tail for direct mounting on to PCB	KMX 3-M 032	KMX 3-F 032
SMT termination	KMX 3-M 172	KMX 3-F 172

EXTRACTION TOOLS

P/N: SD-03000CX003

# TECHNICAL CHARACTERISTICS

MATERIALS & PLATINGS	
<b>Insulator</b>	Diallyl Phtalate UL94vo
<b>Frame</b>	Aluminium Alloy
<b>Contact</b>	Copper Alloy
<b>Guide</b>	Brass + Ni or Stainless steel
<b>Contact plating</b>	Ni + Au

ENVIRONMENTAL	
<b>Temperature range</b>	- 55° C to +125° C
<b>Safety of contact from extraction</b>	Statical 2 mm / 0.079" Dynamical 1.80 mm / 0.071"
<b>Mating cycles</b>	5000
<b>Withdrawal forces</b>	≤ 0.5 N
<b>Special contacts</b>	According to NFC 93569

ELECTRICAL	
<b>Contact resistance</b>	Signal ≤ 12 mΩ
<b>Current rating</b>	Signal 3 A
<b>Insulation</b>	>10 <sup>4</sup> MΩ
<b>Voltage rating</b>	200 V
<b>Proof voltage</b>	800 V
<b>Contact diameter</b>	Signal 0.50 mm
<b>Impedance</b>	Coaxial 50 Ω

Dimension are in mm

# HOW TO ORDER



## 1 ▸ SERIES

## 2 ▸ ARRANGEMENT

100 200

## 3 ▸ PART - POLARITY - PLATING

1 5	Male Plug - MIL plating	2 4	Female Receptacle - MIL plating
1 9	Male Plug - MIL tinned plating	2 8	Female Receptacle - MIL tinned plating

## 4 ▸ TERMINATION STYLES

1 0	90° termination, PCB thickness 1.60	3 0	Straight termination, PCB thickness 2.40	4 4	SMT* - uncentered PCB thickness 3.80
1 1	90° termination, PCB thickness 2.40	3 1	Straight termination, PCB thickness 3.20	9 6	Straight termination, PCB thickness 4.50

## 5 ▸ GUIDE STYLES

1 1 0	MALE POLARISED, TRANSVERSE MOUNT, STANDARD PLUG	1 1 1	MALE POLARISED, VERTICAL MOUNT
1 2 1	FEMALE POLARISED, VERTICAL MOUNT	1 2 2	FEMALE POLARISED, VERTICAL MOUNT
1 2 4	FEMALE POLARISED, TRANSVERSE MOUNT	1 2 5	MALE UNPOLARISED, TRANSVERSE MOUNT
1 2 6	FEMALE UNPOLARISED, VERTICAL MOUNT	1 3 0	FEMALE ALL POLARISED, VERTICAL MOUNT
1 3 1	FEMALE ALL POLARISED, VERTICAL MOUNT	1 3 3	FEMALE ALL POLARISED, TRANSVERSE MOUNT
1 3 4	FEMALE POLARISED, TRANSVERSE MOUNT	1 9 0	FEMALE POWER OR MASS CONTACT, VERTICAL MOUNT
1 9 1	MALE POWER OR MASS CONTACT, TRANSVERSE MOUNT	2 0 1	¼ TURN, FREE CONNECTOR

\* Surface Mount Termination  
PCB thickness is in mm

► MODULES CONFIGURATION

RECEPTACLE - MATING SIDE VIEWS

SINGLE ARRANGEMENTS

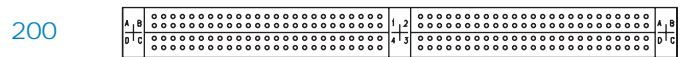
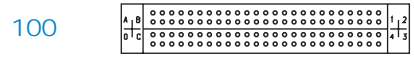

50 ways module

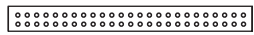

STANDARD PLUGGING STAGES

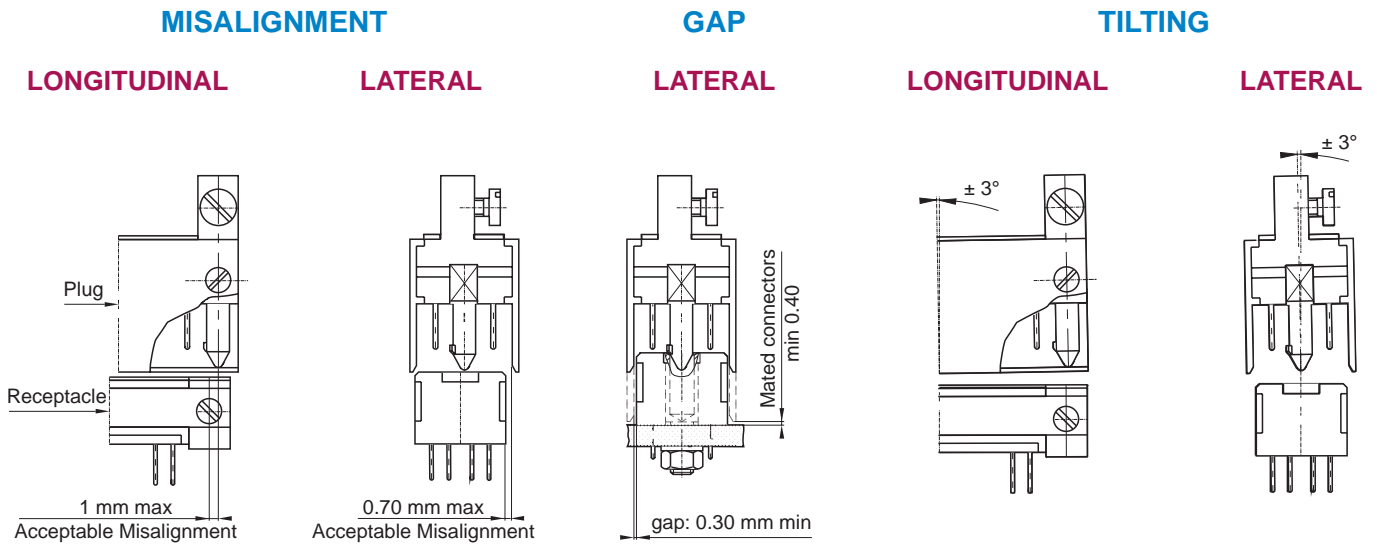

MOUNTING EXAMPLES

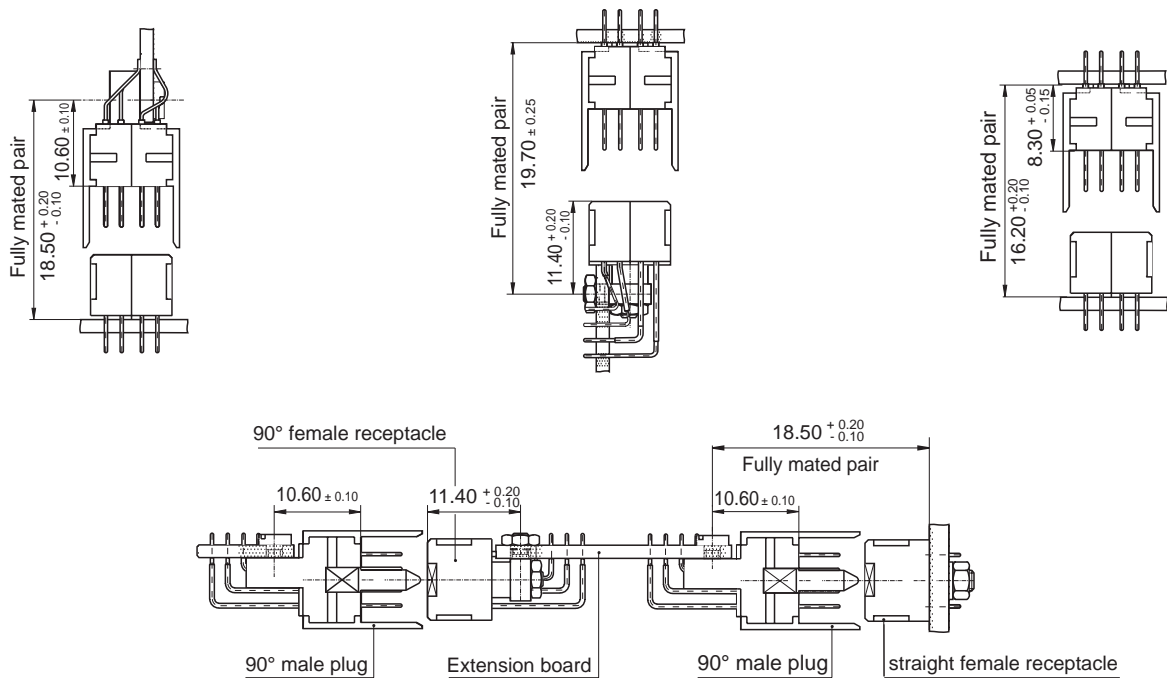

DISPLACEMENT

Max displacement allowed while plugging in the receptacle: 0.15 mm in all plugged in connector ways.



TERMINATION STYLES

RECEPTACLE

THROUGH BOARD SOLDER - 90°

Ref: 10  
PCB: 1.44 - 1.76  
A =  $3.25^{+0.15}_{-0.45}$   
B = 6 max

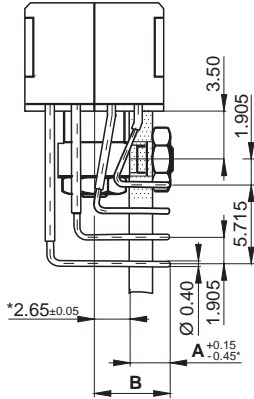

\* Unbuild-up of tolerances

Ref: 11  
PCB: 1.98 - 2.42  
A =  $3.85^{+0.15}_{-0.45}$   
B = 6.60 max

THROUGH BOARD SOLDER - STRAIGHT

Ref: 30  
PCB: 2.16 - 2.64  
A = 3.50 min  
4.00 max

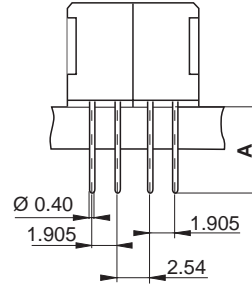

Ref: 31  
PCB: 2.88 - 5.50  
A = 6.10 min  
6.60 max

Ref: 96  
PCB: 3.42 - 4.18  
A = 4.70 min  
5.10 max

PLUG

THROUGH BOARD SOLDER - 90°

Ref: 10  
PCB: 1.44 - 1.76  
A = 5.95 max

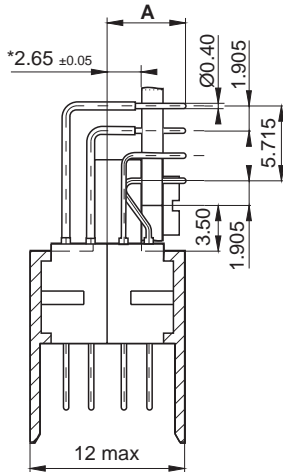

\* Unbuild-up of tolerances

THROUGH BOARD SOLDER - STRAIGHT

Ref: 30  
PCB: 2.16 - 2.64  
A = 3.50 min  
4.00 max

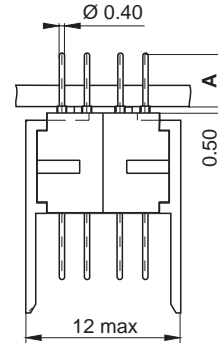

Ref: 31  
PCB: 2.88 - 3.52  
A = 4.60 min  
5.10 max

SURFACE MOUNT (UNCENTERED PCB)

Ref: 44  
PCB: 3.60 - 4.00  
A = 4.40 max

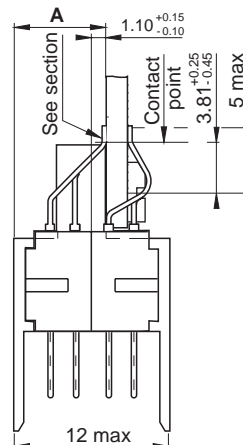

CONNECTOR DIMENSIONS

100 CONTACTS

PLUG

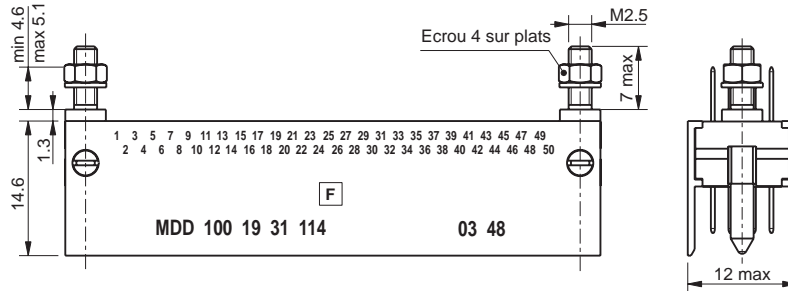

RECEPTACLE

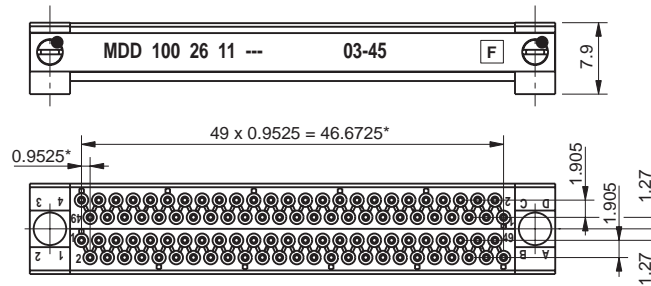

200 CONTACTS

PLUG

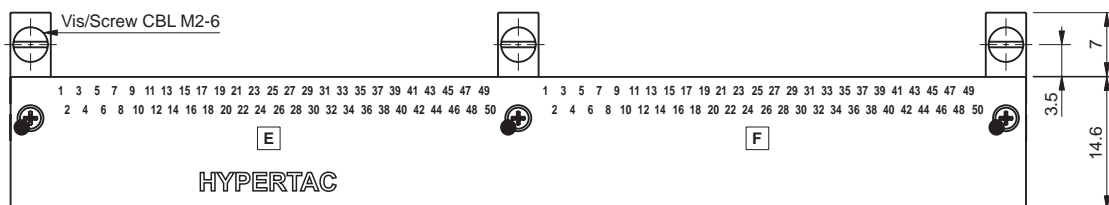

RECEPTACLE

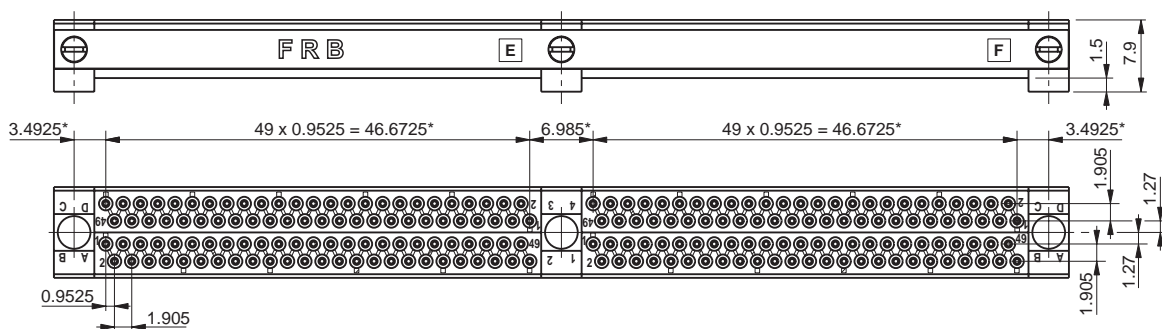

\* Theoretical dimensions

► GUIDING DEVICES

RECEPTACLE

**MHD 00- \_\_ 121**

Polarised female guide vertical mounting (Length: 5.50)

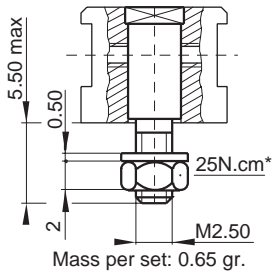

**MHD 00- \_\_ Z122**

Polarised female guide vertical mounting (Length: 7)

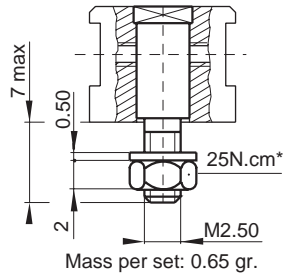

**MHD 00- \_\_ Z124 / Z134**

Polarised female guide transverse mounting P/N 124: A=6; 134: A=6.60

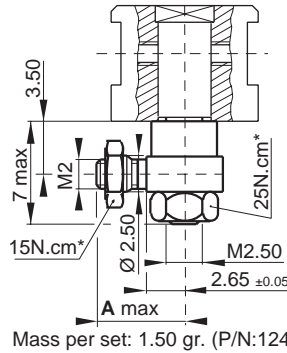

**MHD 00- \_\_ Z126**

Unpolarised female guide vertical mounting

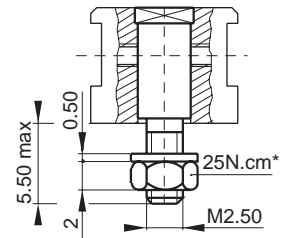

**MHD 00- \_\_ Z130**

All polarity female guide vertical mounting (Length: 5.50)

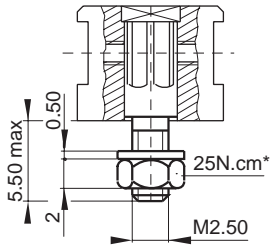

**MHD 00- \_\_ Z131**

All polarity female guide vertical mounting (Length: 7)

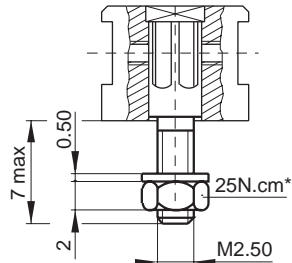

**MHD 00- \_\_ Z133**

All polarity female guide transverse mounting

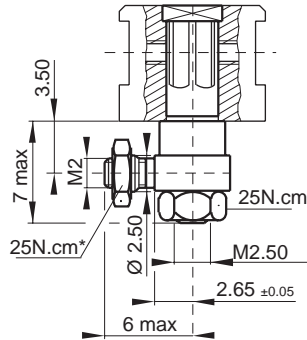

**MHD 00- \_\_ Z190**

Ground female guide vertical mounting

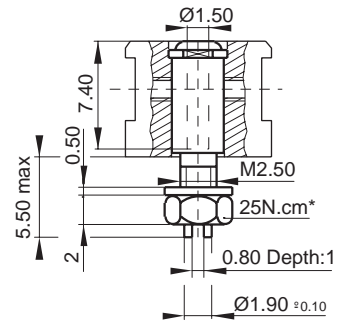

PLUG

**MHD 00- \_\_ 110**

Polarised male guide transverse mounting

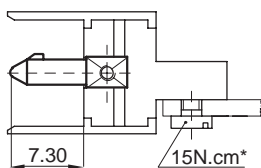

Mass per set: 0.55 gr.

**MHD 00- \_\_ Z111**

Polarised male guide vertical mounting

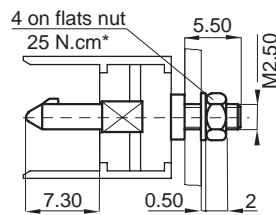

Mass per set: 1.35 gr.

**MHD 00- \_\_ Z125**

Unpolarised male guide transverse mounting

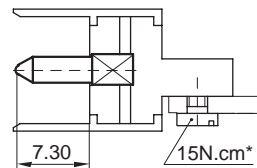

Mass per st: 0.55 gr.

**MHD 00- \_\_ Z191**

Ground male contact transverse mounting

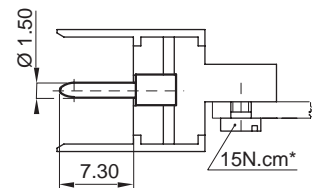

▶ 100 CONTACT BOARD PREPARATION DETAILS <sup>(1)</sup>

RECEPTACLE

STRAIGHT TERMINATION

Guides: 121, 122, 126, 130, 131, 190

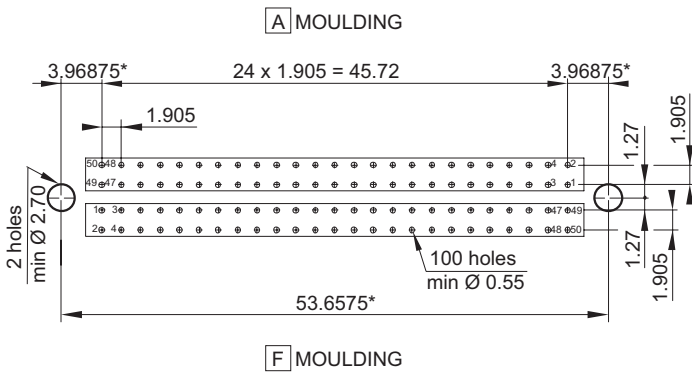

90° TERMINATION

Guides: 124, 133, 134

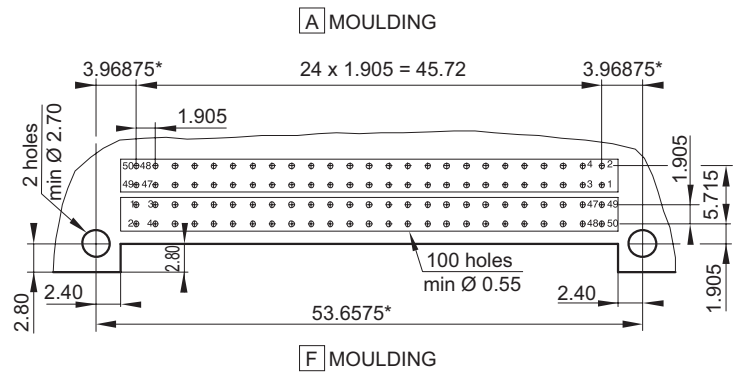

PLUG

STRAIGHT TERMINATION

Guides: 111

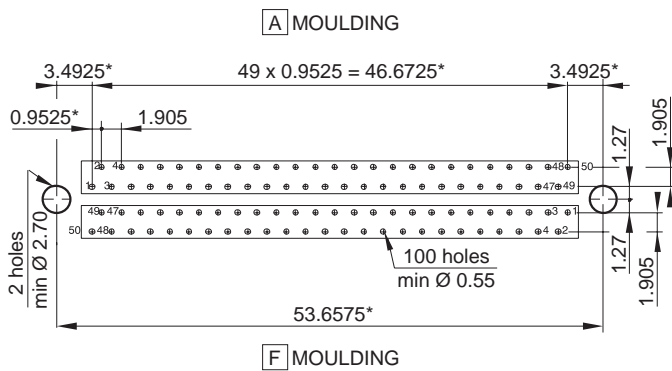

90° TERMINATION

Guides: 110, 125, 191

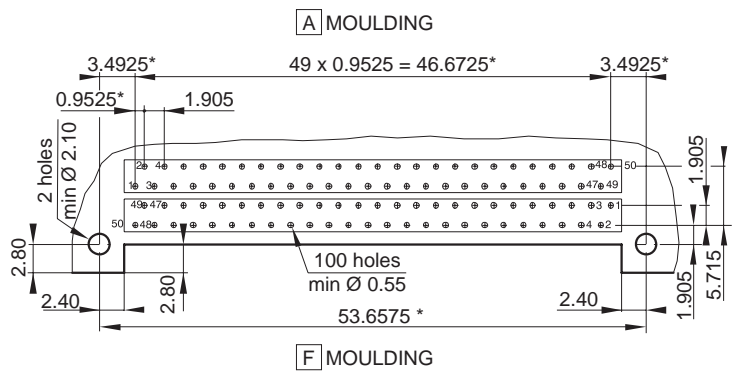

SURFACE MOUNT TERMINATION

Guides: 110, 125, 191

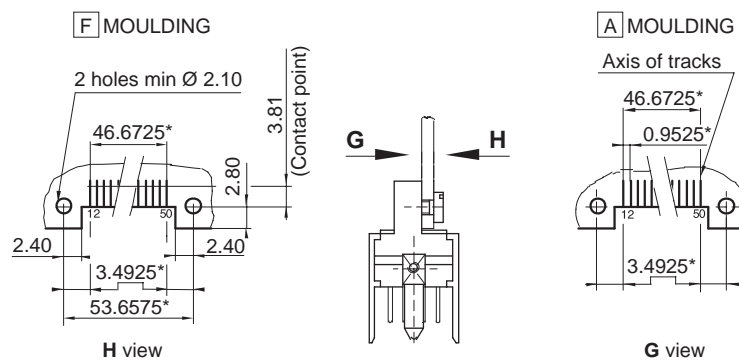

(1) Important note: See important note on 1HB preparation board details (page 17).

\* Theoretical dimensions

# TECHNICAL CHARACTERISTICS

MATERIALS & PLATINGS	
<b>Insulator</b>	Diallyl Phtalate UL94vo
<b>Frame</b>	Aluminium Alloy
<b>Contact</b>	Copper Alloy
<b>Guide</b>	Brass + Ni or Stainless steel
<b>Contact plating</b>	Ni + Au

ENVIRONMENTAL	
<b>Temperature range</b>	- 55° C to +125° C
<b>Safety of contact from extraction</b>	Statical 2 mm / 0.079" Dynamical 1.80 mm / 0.071"
<b>Mating cycle</b>	5000
<b>Withdrawal forces</b>	≤ 0.5 N
<b>Special contacts</b>	According to NFC 93569

ELECTRICAL	
<b>Contact resistance</b>	Signal ≤ 12 mΩ
<b>Current rating</b>	Signal 3 A
<b>Insulation</b>	>10 <sup>4</sup> MΩ
<b>Voltage rating</b>	200 V
<b>Proof voltage</b>	800 V
<b>Contact diameter</b>	Signal 0.50 mm
<b>Impedance</b>	Coaxial 50 Ω

# HOW TO ORDER



1 ▶ SERIES

2 ▶ ARRANGEMENT

200

3 ▶ PART - POLARITY - PLATING

1 9 Male Plug - MIL tinned plating

2 8 Female Receptacle - MIL tinned plating

4 ▶ TERMINATION STYLES

1 0 90° termination, PCB thickness 1.60

4 4 SMT\* - uncentered PCB thickness 3.80

3 1 Straight termination, PCB thickness 3.20

9 6 Straight termination, PCB thickness 4.50

5 ▶ GUIDE STYLES

1 1 4 MALE UNPOLARISED, VERTICAL MOUNT

1 2 2 FEMALE POLARISED, VERTICAL MOUNT

1 2 5 MALE UNPOLARISED, TRANSVERSE MOUNT

1 3 4 FEMALE POLARISED, TRANSVERSE MOUNT

\* Surface Mount Termination  
PCB thickness is in mm

CONNECTOR DIMENSIONS

200 CONTACTS

PLUG

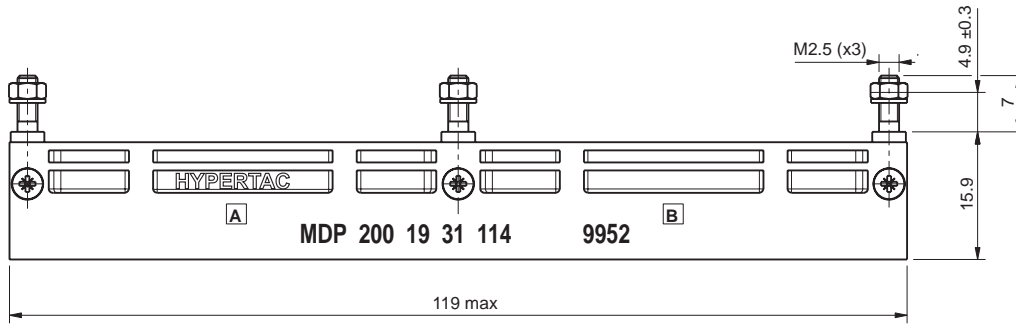

RECEPTACLE

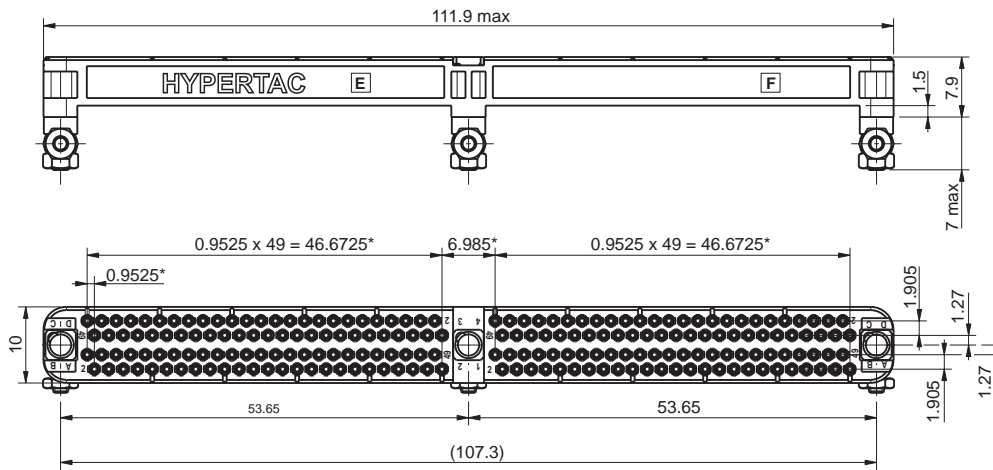

\* Theoretical dimensions

► GUIDE AND TERMINATION STYLES

RECEPTACLE

THROUGH BOARD SOLDER - 90°

Guide: 134

Ref: 10  
PCB: 1.44 - 1.76

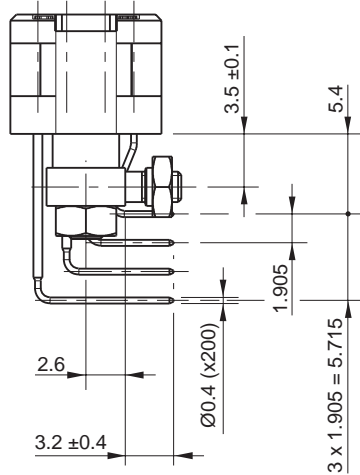

THROUGH BOARD SOLDER - STRAIGHT

Guide: 122

Ref: 96  
PCB: 3.42 - 4.18

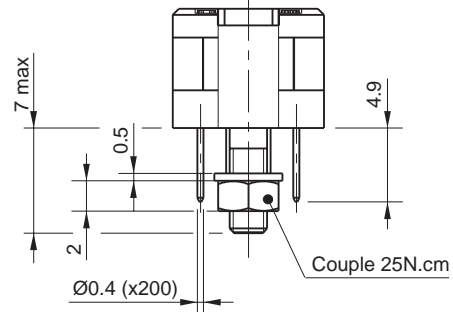

PLUG

THROUGH BOARD SOLDER - STRAIGHT

Guide: 114

Ref: 44  
PCB: 3.60 - 4.00

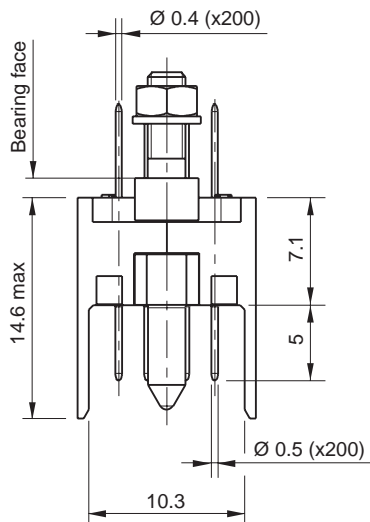

SURFACE MOUNT (UNCENTERED PCB)

Guide: 125

Ref: 81  
PCB: 2.88 - 3.52

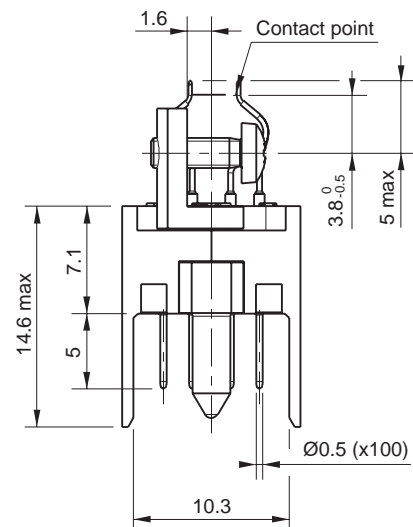

Note: for other guide styles requested, please contact technical support.



200 CONTACT BOARD PREPARATION DETAILS

RECEPTACLE

STRAIGHT TERMINATION

Guide: 122

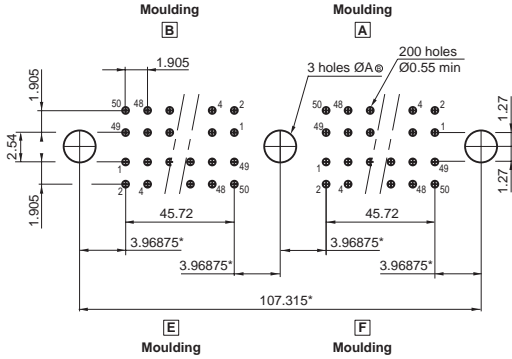

90° TERMINATION

Guide: 184

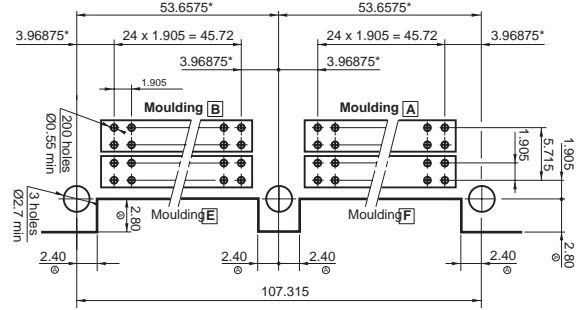

PLUG

STRAIGHT TERMINATION

Guide: 114

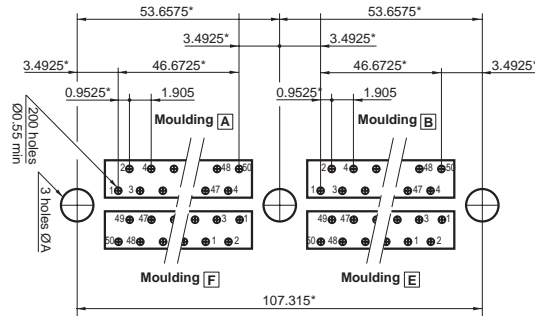

SURFACE MOUNT TERMINATION

Guide: 125

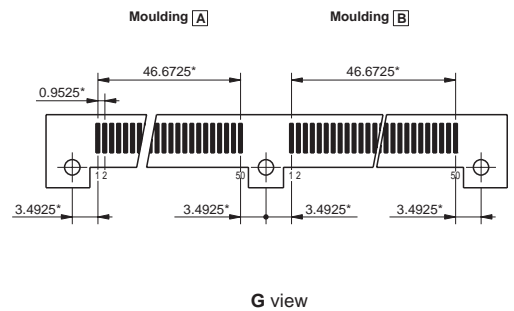
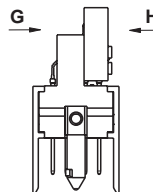
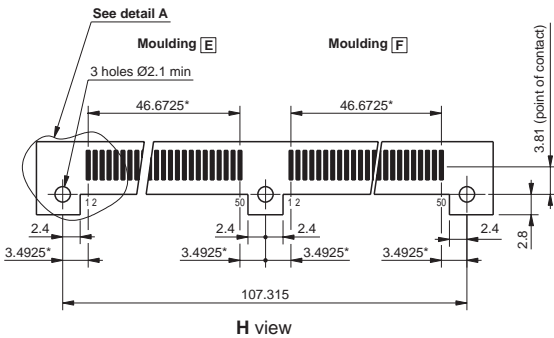

\* Theoretical dimensions

#### **Disclaimer 2014**

All of the information included in this catalogue is believed to be accurate at the time of printing. It is recommended, however, that users should independently evaluate the suitability of each product for their intended application and be sure that each product is properly installed, used and maintained to achieve desired results.

Smiths Connectors makes no warranties as to the accuracy or completeness of the information, and disclaims any liability regarding its use.

Smiths Connectors reserves the right to modify design and specifications, in order to improve quality, keep pace with technological development or meet specific production requirements.

No reproduction or use without express permission of editorial and pictorial content, in any manner.

# SMITHS CONNECTORS PRODUCT LINES

## PCB

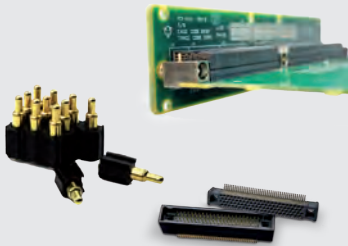

- ▶ Low, medium and high density board-to-board, cable to board and stacking
- ▶ Rugged standard
- ▶ Low profile
- ▶ Signal, power, coaxial & high speed configurations
- ▶ Self configurable board-to-board
- ▶ Spring probe connectors
- ▶ Mixed signal, power and coaxial contact connectors
- ▶ Different termination styles: solder cup, crimp, SMT and SMT flex, press fit, solder dip.

## POWER

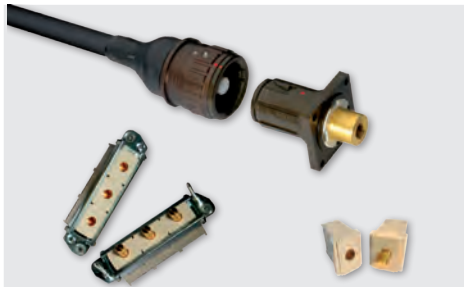

- ▶ Circular
- ▶ Configurable rectangular
- ▶ Ruggedized
- ▶ Single and Multi-Way Connectors
- ▶ Power contact up to 1,200 Amps
- ▶ Excellent performance in harsh environment conditions
- ▶ Cable assembling

## EMI/EMP FILTER

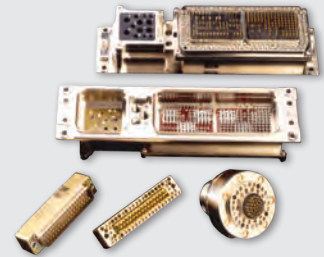

- ▶ EMI/RFI filtering and transient protection
- ▶ RoHS compliant solderless filter connectors available
- ▶ Circular, ARINC, D-Subminiature Micro-D
- ▶ Filtered adapters for "bolt on" EMI /EMP solutions
- ▶ Filter hybrid capability

## MODULAR/RECTANGULAR



- ▶ Configurable with modules for signal, power, coax, fiber optics and/or pneumatics
- ▶ Easy configuration in a single frame
- ▶ For rack & panel, and cable applications
- ▶ Guided hardware for blind
- ▶ D-sub connectors
- ▶ Micro-D style
- ▶ Signal connectors for hand held and docking stations

## CIRCULAR



- ▶ Metal and Plastic
- ▶ Industrial M12, M23, M40, M58
- ▶ Crimp and solder terminations
- ▶ Various types of cable clamps
- ▶ Push Pull/ latch mechanism
- ▶ Color coding

## HEAVY DUTY



- ▶ Ultra reliable hyperboloid contact
- ▶ Modular solution: signal, power, data contacts, and fiber optics
- ▶ High resistance in harsh environment
- ▶ EMC shielding
- ▶ Easy cable mounting
- ▶ High pressure up to 35K PSI, 250° C
- ▶ High temperature up to 440°C

## SPRING PROBES

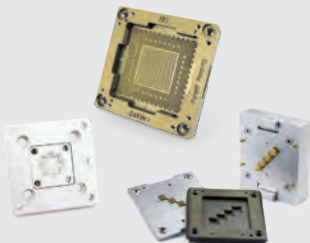

- ▶ Z-axis compliant
- ▶ Blind mate engagement
- ▶ Long cycle life
- ▶ High density
- ▶ Extreme miniaturization
- ▶ Printed circuit board test
- ▶ Bare board test
- ▶ Coaxial contacts

## MIL/AERO STANDARD



- ▶ Standard military interface
- ▶ ARINC interface
- ▶ ARINC 801
- ▶ Custom inserts

## HIGH SPEED COPPER/FIBER

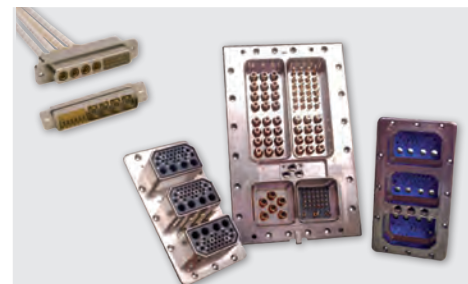

- ▶ Quadrx and Twinax Connectors
- ▶ Rugged D-Sub Connectors
- ▶ ARINC and MIL-STD Contacts
- ▶ Micro Twinax/Quadrx
- ▶ Butt-Joint and Expanded Beam Contacts
- ▶ ARINC 801 Termini
- ▶ Floating Fiber Termini

# SMITHS CONNECTORS GLOBAL SUPPORT

## AMERICAS

Hudson, MA  
Costa Mesa, CA  
Kansas City, KS

1.978.568.0451  
1.714.371.1100  
1.913.342.5544

info@hypertronics.com  
customerservice@sabritec.com  
info@idinet.com

## EUROPE

France  
Germany  
Italy  
United Kingdom

33.2.32969176  
49.991.250120  
39.010.60361  
44.208.236.2400

info@hypertac.fr  
info@hypertac.de  
info@hypertac.it  
info@hypertac.co.uk

## ASIA

Shanghai, China  
Singapore  
Suzhou, China

65.6846.1655  
65.6846.1655  
65.6846.1655

asiacrs@smithsconnectors.com  
asiacrs@smithsconnectors.com  
asiacrs@smithsconnectors.com

FOR MORE INFORMATION | [smithsconnectors.com](http://smithsconnectors.com) |    